



Eppinger Werkzeughalter
OKUMA LB 2000/2500/3000 EX (MW) (Direkt)
Drehen

Feststehende/Angetriebene Werkzeughalter

Wir geben Ihnen das beste Werkzeug an die Hand We offer you the best tool available

Seit 90 Jahren ist Eppinger bei Fachleuten ein Begriff für Präzision, Innovation und Zuverlässigkeit. In knapp einem Jahrhundert haben wir ein einzigartiges Know-how in der Werkzeugfertigung erworben und erweitert. Heute profitieren Anwender überall auf der Welt von der Flexibilität und Leistungsfähigkeit unserer Werkzeugsysteme. Mit außergewöhnlichem Engagement sorgen wir dafür, dass Sie die besten Werkzeuge bekommen – zur richtigen Zeit, am richtigen Ort.

For over 90 years Eppinger has been known among the industry's experts as **the name for precision, innovation and dependability. For almost a century a one-of-a-kind know-how in manufacturing tools has been developed and expanded. During this time our worldwide users have profited from the flexibility and capabilities of our tooling systems. We make sure you will receive the best tools through our exceptional user interface, when you need them, and where you need them.**



Qualität mit der Sie rechnen können

Innovation und Optimierung – diese beiden Säulen prägen seit den Anfangstagen die Philosophie bei Eppinger. Heute sind wir mit rund 450 Mitarbeitern einer der Weltmarktführer in der Branche. Unsere Werkzeughalter und Werkzeugsysteme werden mit sehr großer Fertigungstiefe und unter Einhaltung strengster Qualitätsstandards produziert. Das Ergebnis sind hochpräzise Werkzeuge mit herausragenden Standzeiten.



Zwei Faktoren, die Ihre Stückkosten nachhaltig senken können und die Qualität Ihrer Produkte sichern.

Quality you can count on

Innovation and optimization, these pillars have been Eppinger's philosophy from our beginnings. Today, with over 450 employees we are one of the world's market leaders in this field. Our tool holders and tooling systems are manufactured using our vertically integrated manufacturing processes combined with the toughest quality control standards. This results in extremely precise tools with outstanding longevity.





Two factors that reduce your parts cost and increase the quality of your product.

Inhaltsverzeichnis Table of contents

(A) Feststehende Werkzeughalter Fixed tool holder

Seite/
Page

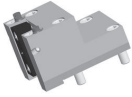
Drehmeißel Turning tools

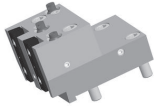
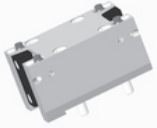
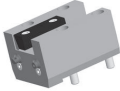
	Werkzeughalter/Tool holder gerade, links versetzt Vierkantaufnahme, Kühlmittel extern straight, left hand offset rectangular transverse, external coolant supply	10
	Werkzeughalter/Tool holder gerade, links versetzt Vierkantaufnahme, Kühlmittel extern straight, left hand offset rectangular transverse, external coolant supply	10
	Werkzeughalter/Tool holder gerade, mehrfach Vierkantaufnahme, Kühlmittel extern straight, multiple rectangular transverse, Coolant external	11
	Werkzeughalter/Tool holder gerade, mehrfach Vierkantaufnahme, Kühlmittel extern straight, multiple rectangular transverse, Coolant external	11
	Werkzeughalter/Tool holder gerade, mehrfach Vierkantaufnahme, Kühlmittel extern und zentral straight, multiple rectangular lengthwise, Coolant external and central	12
	Werkzeughalter/Tool holder abgewinkelt, links-rechts Vierkantaufnahme, Kühlmittel extern angular, left hand-right hand rectangular transverse, external coolant supply	12

Abstechwerkzeuge und Einstechwerkzeuge Cut-off tool and plunging tool

	Abstechhalter/Cut-off tool holder Drehrichtung universal Kühlmittel extern und zentral Schwerhöhe H=26 direction of rotation universal external and central coolant supply tool height H=26	13
-------------------------------------------------------------------------------------	----------------------------------------------------------------------------------------------------------------------------------------------------------------------------------------------------------	----

Zylinderbohrung Cylindrical chucks for drills/ mills

	Bohrstangenhalter/Boring bar holder abgewinkelt, links-rechts Zylinderaufnahme Ø40 Kühlmittel extern und zentral angular, left hand - right hand cylindrical chuck Ø40 external and central coolant supply	13
-------------------------------------------------------------------------------------	-------------------------------------------------------------------------------------------------------------------------------------------------------------------------------------------------------------------------	----

(A) Feststehende Werkzeughalter Fixed tool holder

Seite/
Page

Zylinderbohrung Cylindrical chucks for drills/ mills

	<p>Bohrstangenhalter/Boring bar holder abgewinkelt, links-rechts, mehrfach Zylinderaufnahme Ø25, Kühlmittel extern angular, left hand - right hand, multiple cylindrical chuck Ø25, external coolant supply</p>	14
	<p>Bohrstangenhalter/Boring bar holder abgewinkelt, links-rechts, mehrfach Zylinderaufnahme Ø40 und Ø25, Kühlmittel extern und zentral angular, left hand - right hand, multiple cylindrical chuck Ø40 and Ø25, external and central coolant supply</p>	14
	<p>Bohrstangenhalter/Boring bar holder abgewinkelt, links-rechts, mehrfach Zylinderaufnahme Ø40, Kühlmittel extern und zentral angular, left hand - right hand, multiple cylindrical chuck Ø40, external and central coolant supply</p>	15
	<p>Bohrstangenhalter/Boring bar holder abgewinkelt, links-rechts, mehrfach Zylinderaufnahme Ø32 Kühlmittel extern und zentral angular, left hand - right hand, multiple cylindrical chuck Ø32 external and central coolant supply</p>	15

EPPINGER PSC EPPINGER PSC

	<p>Werkzeughalter/Tool holder gerade Schnellwechselsystem, EPPINGER PSC 40, RH Kühlmittel extern und zentral angular, straight quick change, EPPINGER PSC 40, RH external and central coolant supply</p>	16
	<p>Werkzeughalter/Tool holder gerade Schnellwechselsystem, EPPINGER PSC 40, LH Kühlmittel extern und zentral angular, straight quick change, EPPINGER PSC 40, LH external and central coolant supply</p>	16
	<p>Werkzeughalter/Tool holder gerade, mehrfach Schnellwechselsystem, EPPINGER PSC 40, RH Kühlmittel extern und zentral straight, multiple quick change, EPPINGER PSC 40, RH external and central coolant supply</p>	17
	<p>Werkzeughalter/Tool holder gerade, mehrfach Schnellwechselsystem, EPPINGER PSC 40, LH Kühlmittel extern und zentral straight, multiple quick change, EPPINGER PSC 40, LH external and central coolant supply</p>	17

(A) Feststehende Werkzeughalter Fixed tool holder

Seite/
Page

EPPINGER PSC
EPPINGER PSC

	<p>Werkzeughalter/Tool holder abgewinkelt Schnellwechselsystem, EPPINGER PSC 40, LH Kühlmittel extern und zentral angular quick change, EPPINGER PSC 40, LH external and central coolant supply</p>	<p>18</p>
	<p>Werkzeughalter/Tool holder abgewinkelt Schnellwechselsystem, EPPINGER PSC 40, RH Kühlmittel extern und zentral angular quick change, EPPINGER PSC 40, RH external and central coolant supply</p>	<p>18</p>
	<p>Werkzeughalter/Tool holder abgewinkelt Schnellwechselsystem, EPPINGER PSC 40, RH Kühlmittel extern und zentral angular quick change, EPPINGER PSC 40, RH external and central coolant supply</p>	<p>19</p>
	<p>Werkzeughalter/Tool holder abgewinkelt Schnellwechselsystem, EPPINGER PSC 40, LH Kühlmittel extern und zentral angular quick change, EPPINGER PSC 40, LH external and central coolant supply</p>	<p>19</p>
	<p>Werkzeughalter/Tool holder abgewinkelt Schnellwechselsystem, EPPINGER PSC 40, RH Kühlmittel extern und zentral angular quick change, EPPINGER PSC 40, RH external and central coolant supply</p>	<p>20</p>
	<p>Werkzeughalter/Tool holder abgewinkelt Schnellwechselsystem, EPPINGER PSC 40, LH Kühlmittel extern und zentral angular quick change, EPPINGER PSC 40, LH external and central coolant supply</p>	<p>20</p>
	<p>Werkzeughalter/Tool holder abgewinkelt, mehrfach Schnellwechselsystem, EPPINGER PSC 40, RH Kühlmittel extern und zentral angular, multiple quick change, EPPINGER PSC 40, RH external and central coolant supply</p>	<p>21</p>
	<p>Werkzeughalter/Tool holder abgewinkelt, mehrfach Schnellwechselsystem, EPPINGER PSC 40, LH Kühlmittel extern und zentral angular, multiple quick change, EPPINGER PSC 40, LH external and central coolant supply</p>	<p>21</p>

(A) Feststehende Werkzeughalter Fixed tool holder

Seite/
Page

EPPINGER PSC
EPPINGER PSC



Werkzeughalter/Tool holder

abgewinkelt, mehrfach Schnellwechselsystem, EPPINGER PSC 40, RH Kühlmittel extern und zentral
angular, multiple quick change, EPPINGER PSC 40, RH external and central coolant supply

Bestellnummer/Part Number **7.077.108**

22

Sonstige Eigenschaften other features



Schutzstopfen/Blanking plug

Bestellnummer/Part Number **7.073.475**

22



Bohrstangenhalter Rohling/Boring bar holder Pre-machined blank

Bestellnummer/Part Number **7.074.974**

23

(B) Angetriebene Werkzeughalter Rotary tool holder

Seite/
Page

Spannzange / PRECI-FLEX®
Collet chuck / PRECI-FLEX®

	<p>Bohr- Fräskopf/Drilling and milling head gerade Spannzangenaufnahme, ER32A, PRECI-FLEX®, Kühlmittel extern straight collet chuck, ER32A, PRECI-FLEX®, external coolant supply</p>	24
	<p>Bohr- Fräskopf/Drilling and milling head gerade Spannzangenaufnahme, ER32A, PRECI-FLEX® Kühlmittel extern und zentral straight collet chuck, ER32A, PRECI-FLEX® external and central coolant supply</p>	24

Spannzange
Collet chuck

	<p>Bohr- Fräskopf/Drilling and milling head gerade Spannzangenaufnahme, ER32A, PRECI-FLEX®, CC, Hochdruck Kühlmittel zentral straight collet chuck, ER32A, PRECI-FLEX®, CC, high pressure central coolant supply</p>	25
--	-------------------------------------------------------------------------------------------------------------------------------------------------------------------------------------------------------------------------------------	----

Spannzange / PRECI-FLEX®
Collet chuck / PRECI-FLEX®

	<p>Bohr- Fräskopf/Drilling and milling head gerade, doppelt Spannzangenaufnahme, ER20A, PRECI-FLEX® Kühlmittel extern Ausrichtung zur Hauptspindel straight, double collet chuck, ER20A, PRECI-FLEX® external coolant supply</p>	25
	<p>Bohr- Fräskopf/Drilling and milling head gerade, doppelt Spannzangenaufnahme, ER20A, PRECI-FLEX® Kühlmittel extern und zentral straight, double collet chuck, ER20A, PRECI-FLEX® external and central coolant supply</p>	26
	<p>Bohr- Fräskopf/Drilling and milling head gerade, doppelt Spannzangenaufnahme, ER20A, PRECI-FLEX® Kühlmittel extern Ausrichtung in Haupt- und Gegenspindel straight, double collet chuck, ER20A, PRECI-FLEX® external coolant supply</p>	26
	<p>Bohr- Fräskopf/Drilling and milling head abgewinkelt, links-rechts Spannzangenaufnahme, ER32A, PRECI-FLEX®, Kühlmittel extern angular, left hand - right hand collet chuck, ER32A, PRECI-FLEX®, external coolant supply</p>	27
	<p>Bohr- Fräskopf/Drilling and milling head abgewinkelt, doppelseitig Spannzangenaufnahme, ER32A, PRECI-FLEX®, Kühlmittel extern angular, double sided collet chuck, ER32A, PRECI-FLEX®, external coolant supply</p>	27

(B) Angetriebene Werkzeughalter Rotary tool holder

Seite/
Page

Spannzange / PRECI-FLEX®
Collet chuck / PRECI-FLEX®

	<p>Bohr- Fräskopf/Drilling and milling head abgewinkelt, links, kurz Spannzangenaufnahme, ER25A, PRECI-FLEX®, Kühlmittel extern angular, left hand, short collet chuck, ER25A, PRECI-FLEX®, external coolant supply</p>	28
	<p>Bohr- Fräskopf/Drilling and milling head abgewinkelt, doppelseitig Spannzangenaufnahme, ER32A, PRECI-FLEX® Kühlmittel extern und zentral angular, double sided collet chuck, ER32A, PRECI-FLEX external and central coolant supply</p>	28

EPPINGER PSC
EPPINGER PSC

	<p>Bohr- Fräskopf/Drilling and milling head abgewinkelt, doppelseitig Schnellwechselsystem, EPPINGER PSC 40 Kühlmittel extern straight, angular, left hand - right hand quick change, EPPINGER PSC 40 external coolant supply</p>	29
--	--------------------------------------------------------------------------------------------------------------------------------------------------------------------------------------------------------------------------------------------------	----

Spannzange / PRECI-FLEX®
Collet chuck / PRECI-FLEX®

	<p>Bohr- Fräskopf/Drilling and milling head abgewinkelt, links-rechts Spannzangenaufnahme, ER32A, PRECI-FLEX® Kühlmittel extern und zentral angular, left hand - right hand collet chuck, ER32A, PRECI-FLEX® external and central coolant supply</p>	29
	<p>Bohr- Fräskopf/Drilling and milling head abgewinkelt, links-rechts Spannzangenaufnahme, ER32A, PRECI-FLEX®, Hochdruck Kühlmittel extern und zentral angular, left hand - right hand collet chuck, ER32A, PRECI-FLEX®, high pressure external and central coolant supply</p>	30
	<p>Bohr- Fräskopf/Drilling and milling head abgewinkelt, doppelt Spannzangenaufnahme, ER20A, PRECI-FLEX® Kühlmittel extern angular, double sided collet chuck, ER20A, PRECI-FLEX® external coolant supply</p>	30
	<p>Bohr- Fräskopf/Drilling and milling head abgewinkelt, doppelt Spannzangenaufnahme, ER20A, PRECI-FLEX® Kühlmittel extern und zentral angular, double collet chuck, ER20A, PRECI-FLEX® external and central coolant supply</p>	31
	<p>Bohr- Fräskopf/Drilling and milling head gerade, winkelverstellbar Spannzangenaufnahme, ER20A, PRECI-FLEX®, Kühlmittel extern straight, angular adjustable collet chuck, ER20A, PRECI-FLEX®, external coolant supply</p>	31

(B) Angetriebene Werkzeughalter Rotary tool holder

Seite/
Page

EPPINGER PSC EPPINGER PSC

	<p>Bohr- Fräskopf/Drilling and milling head gerade Schnellwechselsystem, EPPINGER PSC 40 Kühlmittel extern straight quick change, EPPINGER PSC 40 external coolant supply</p>	<p>32</p>
	<p>Bohr- Fräskopf/Drilling and milling head gerade Schnellwechselsystem, EPPINGER PSC 40 Kühlmittel extern und zentral straight quick change, EPPINGER PSC 40 external and central coolant supply</p>	<p>32</p>
	<p>Bohr- Fräskopf/Drilling and milling head abgewinkelt, links-rechts Schnellwechselsystem, EPPINGER PSC 40 Kühlmittel extern straight, angular, left hand - right hand quick change, EPPINGER PSC 40 external coolant supply</p>	<p>33</p>
	<p>Bohr- Fräskopf/Drilling and milling head abgewinkelt, links-rechts Schnellwechselsystem, EPPINGER PSC 40 Kühlmittel extern und zentral angular, left hand - right hand quick change, EPPINGER PSC 40 external and central coolant supply</p>	<p>33</p>

Schnellwechselsystem (z.B. : SK, BT, CAT) Quick change tooling systems

	<p>Stosshalter/Shaping Tool Holder</p>	<p>34</p>
-------------------------------------------------------------------------------------	-----------------------------------------------	------------------

Kreissägen mit Gegenlager Slotting saws

	<p>Kreissägehalter Fräserdornaufnahme Ø22/Spindle unit for side milling cutters chuck for cutter arbor Ø22 Kühlmittel extern external coolant supply</p>	<p>34</p>
-------------------------------------------------------------------------------------	-------------------------------------------------------------------------------------------------------------------------------------------------------------------------	------------------

(C) Adapter Adapter

35

(A) Feststehende Werkzeughalter Fixed tool holder

Drehmeißel
Turning tools

Werkzeughalter, gerade, links versetzt Vierkantaufnahme, Kühlmittel extern
Tool holder, straight, left hand offset rectangular transverse, external coolant supply

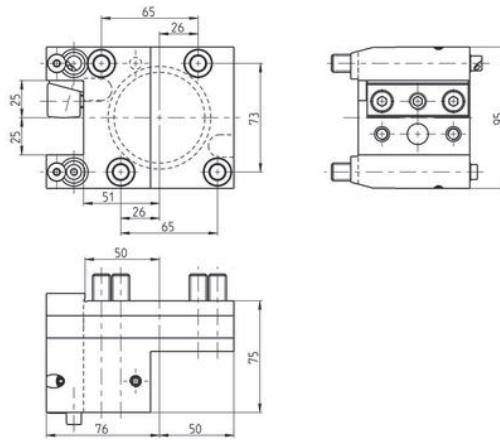
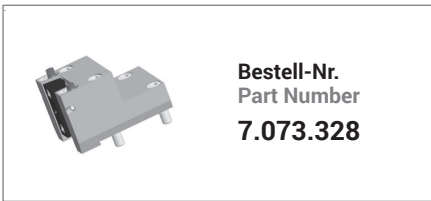

Werkzeughalter, gerade, links versetzt Vierkantaufnahme, Kühlmittel extern
Tool holder, straight, left hand offset rectangular transverse, external coolant supply

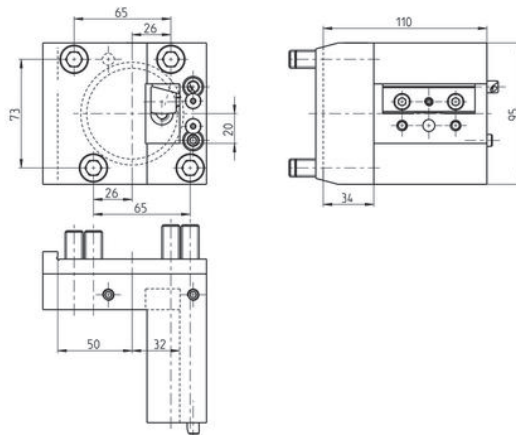
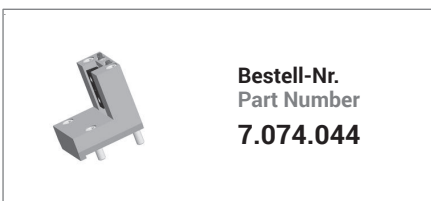

(A) Feststehende Werkzeughalter Fixed tool holder

Drehmeißel
Turning tools

Werkzeughalter, gerade, mehrfach Vierkantaufnahme, Kühlmittel extern
Tool holder, straight, multiple rectangular transverse, Coolant external

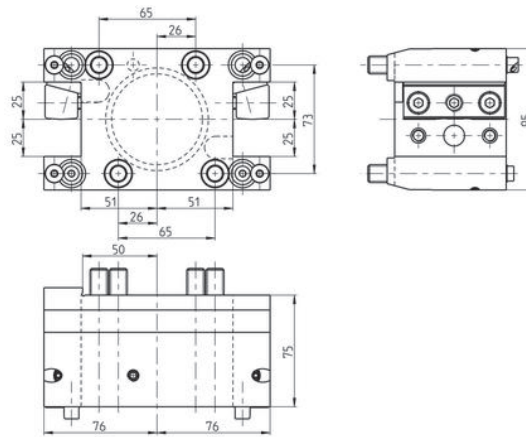

Werkzeughalter, gerade, mehrfach Vierkantaufnahme, Kühlmittel extern
Tool holder, straight, multiple rectangular transverse, Coolant external

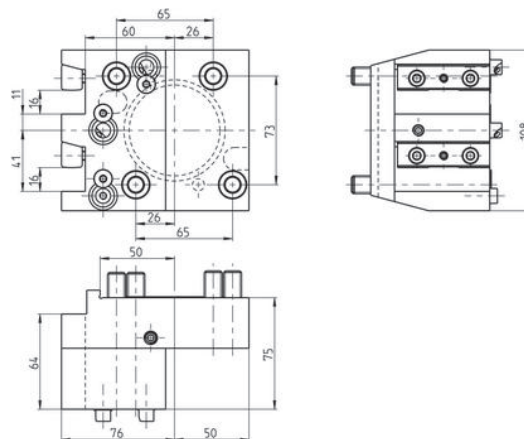
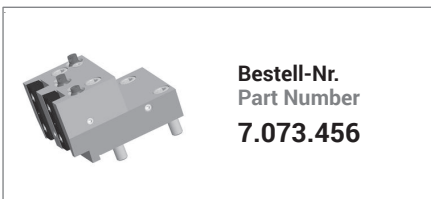

(A) Feststehende Werkzeughalter Fixed tool holder

Drehmeißel
Turning tools

Werkzeughalter, gerade, mehrfach Vierkantaufnahme, Kühlmittel extern und zentral
Tool holder, straight, multiple rectangular lengthwise, Coolant external and central

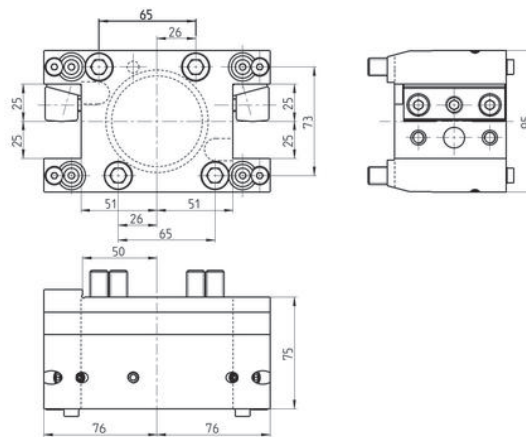
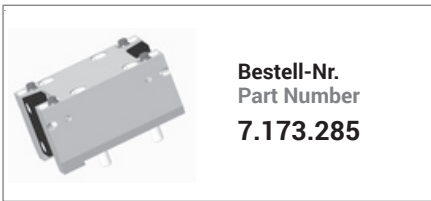

Werkzeughalter, abgewinkelt, links-rechts Vierkantaufnahme, Kühlmittel extern
Tool holder, angular, left hand-right hand rectangular transverse, external coolant supply

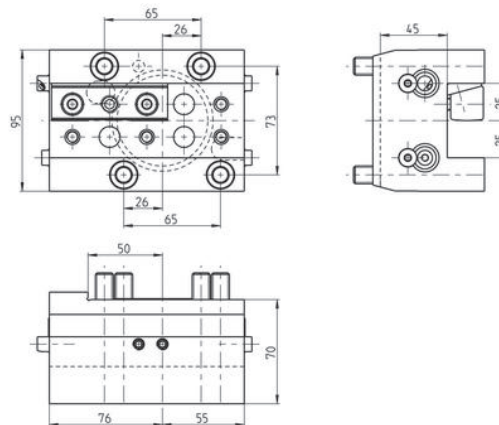
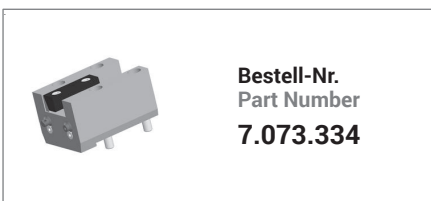

(A) Feststehende Werkzeughalter Fixed tool holder

Abstechwerkzeuge und Einstechwerkzeuge
Cut-off tool and plunging tool

Abstechhalter, Drehrichtung universal Kühlmittel extern und zentral Schwerhöhe H=26
Cut-off tool holder, direction of rotation universal external and central coolant supply tool height H=26

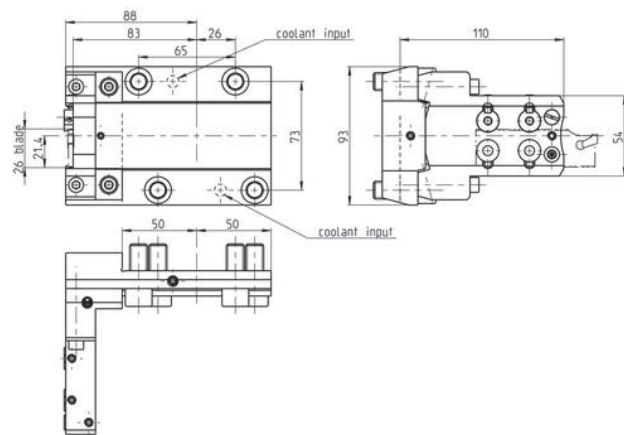
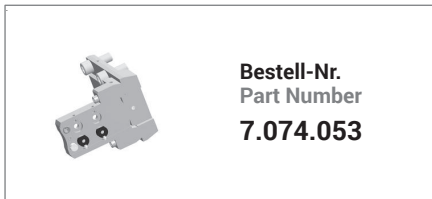

Zylinderbohrung
Cylindrical chucks for drills/ mills

Bohrstangenhalter, abgewinkelt, links-rechts Zylinderaufnahme Ø40 Kühlmittel extern und zentral
Boring bar holder, angular, left hand - right hand cylindrical chuck Ø40 external and central coolant supply

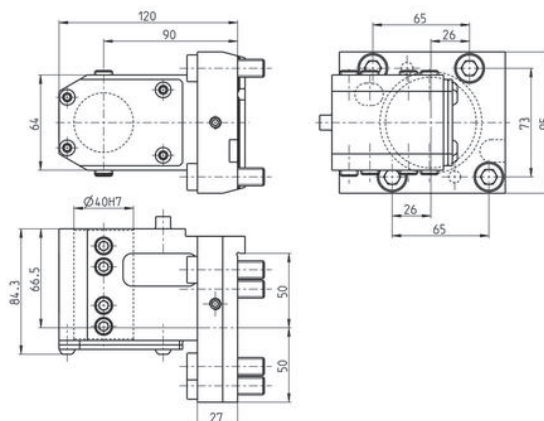
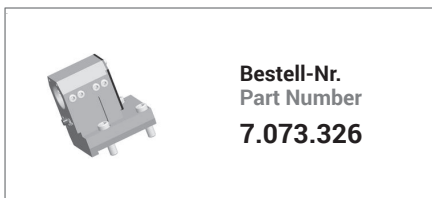

Zubehör
Accessories

Reduzierbuchsen Ausführung F und M
siehe Zubehör für Werkzeughalter Z5.1

Bushing Type F and M
see Equipment for Toolholders Z5.1

(A) Feststehende Werkzeughalter Fixed tool holder

Zylinderbohrung
Cylindrical chucks for drills/ mills

Bohrstangenhalter, abgewinkelt, links-rechts, mehrfach Zylinderaufnahme Ø25, Kühlmittel extern
Boring bar holder, angular, left hand - right hand, multiple cylindrical chuck Ø25, external coolant supply



Bestell-Nr.
Part Number
7.073.458

Zubehör
Accessories

Reduzierbuchsen Ausführung E
siehe Zubehör für Werkzeughalter Z5.1

Bushing Type E
see Equipment for Toolholders Z5.1

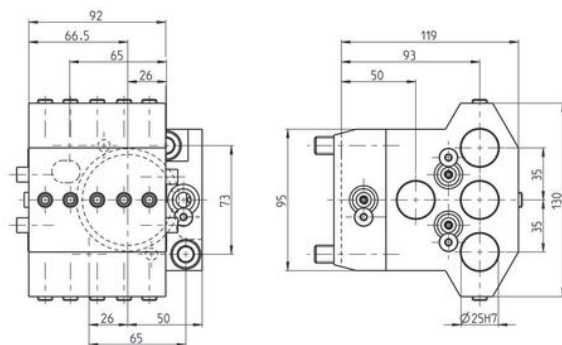

Bohrstangenhalter, abgewinkelt, links-rechts, mehrfach Zylinderaufnahme Ø40 und Ø25, Kühlmittel extern und zentral
Boring bar holder, angular, left hand - right hand, multiple cylindrical chuck Ø40 and Ø25, external and central coolant supply

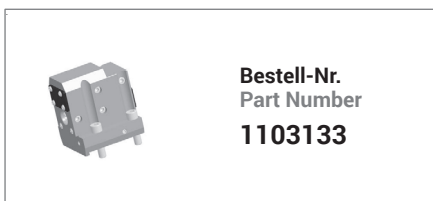

Bestell-Nr.
Part Number
1103133

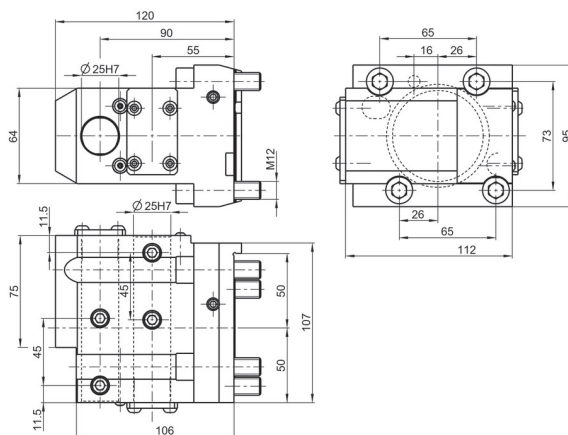

(A) Feststehende Werkzeughalter Fixed tool holder

Zylinderbohrung
Cylindrical chucks for drills/ mills

Bohrstangenhalter, abgewinkelt, links-rechts, mehrfach Zylinderaufnahme Ø40, Kühlmittel extern und zentral
Boring bar holder, angular, left hand - right hand, multiple cylindrical chuck Ø40, external and central coolant supply

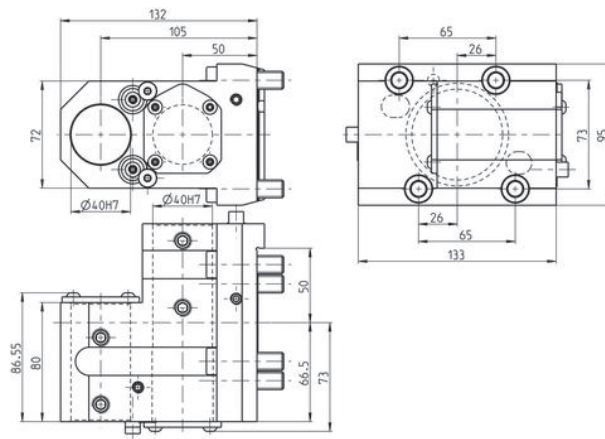
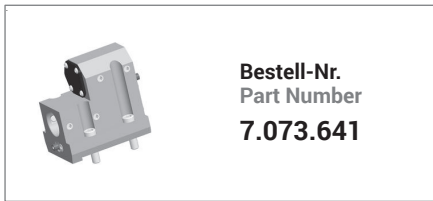

Bohrstangenhalter, abgewinkelt, links-rechts, mehrfach Zylinderaufnahme Ø32 Kühlmittel extern und zentral
Boring bar holder, angular, left hand - right hand, multiple cylindrical chuck Ø32 external and central coolant supply

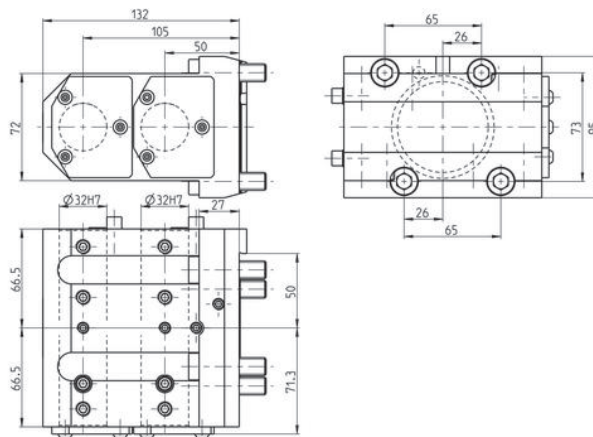
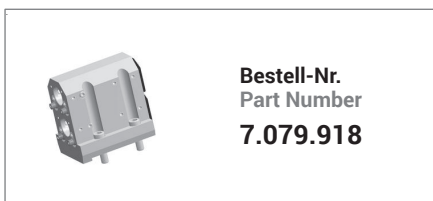

(A) Feststehende Werkzeughalter Fixed tool holder

EPPINGER PSC
EPPINGER PSC

Werkzeughalter, gerade Schnellwechselsystem, EPPINGER PSC 40, RH Kühlmittel extern und zentral
Tool holder, angular, straight quick change, EPPINGER PSC 40, RH external and central coolant supply

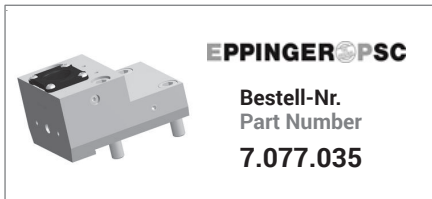

Zubehör
Accessories

Rohrverschraubung 0.000.377

Coolant tubes 0.000.377

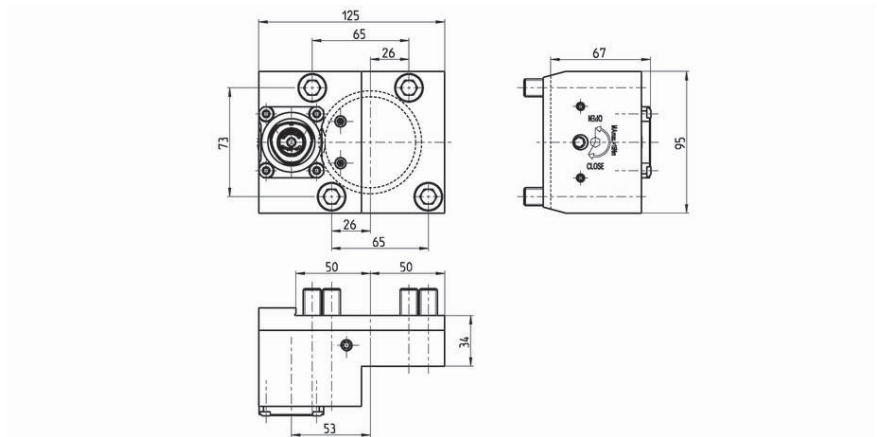

Werkzeughalter, gerade Schnellwechselsystem, EPPINGER PSC 40, LH Kühlmittel extern und zentral
Tool holder, angular, straight quick change, EPPINGER PSC 40, LH external and central coolant supply

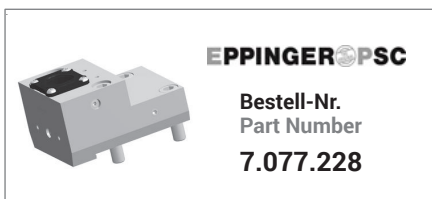

Zubehör
Accessories

Rohrverschraubung 0.000.377

Coolant tubes 0.000.377

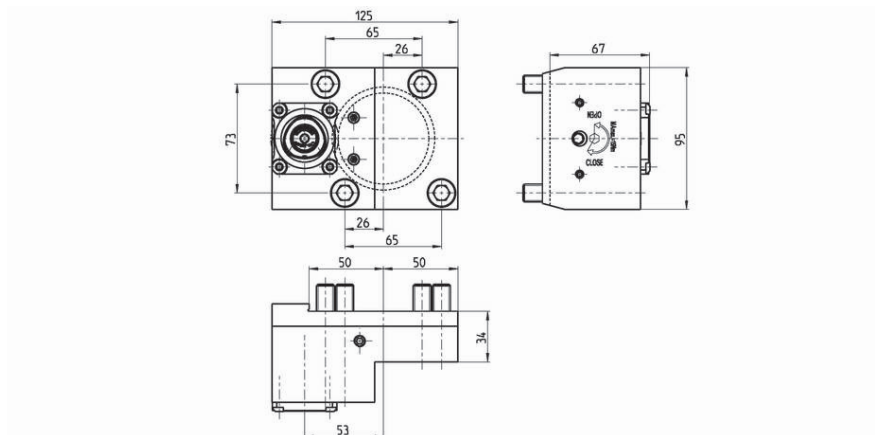

(A) Feststehende Werkzeughalter Fixed tool holder

EPPINGER PSC
EPPINGER PSC

Werkzeughalter, gerade, mehrfach Schnellwechselsystem, EPPINGER PSC 40, RH Kühlmittel extern und zentral
Tool holder, straight, multiple quick change, EPPINGER PSC 40, RH external and central coolant supply



Zubehör
Accessories

Rohrverschraubung 0.000.377

Coolant tubes 0.000.377

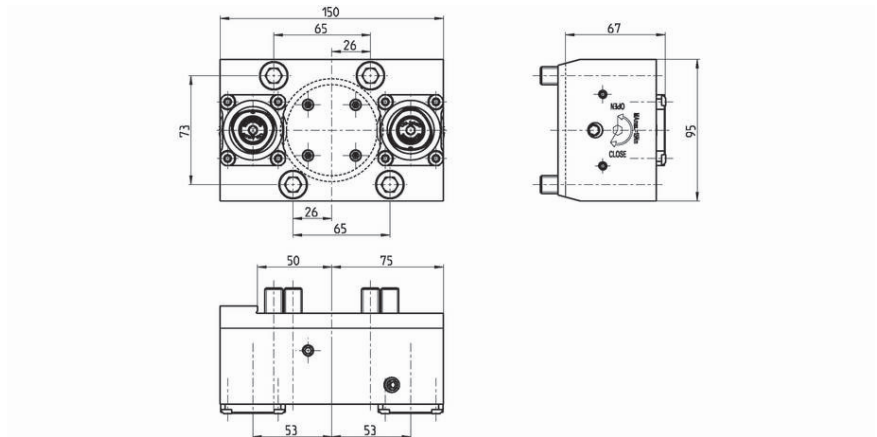

Werkzeughalter, gerade, mehrfach Schnellwechselsystem, EPPINGER PSC 40, LH Kühlmittel extern und zentral
Tool holder, straight, multiple quick change, EPPINGER PSC 40, LH external and central coolant supply

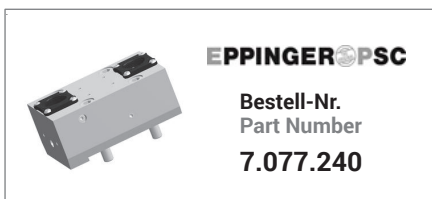

Zubehör
Accessories

Rohrverschraubung 0.000.377

Coolant tubes 0.000.377

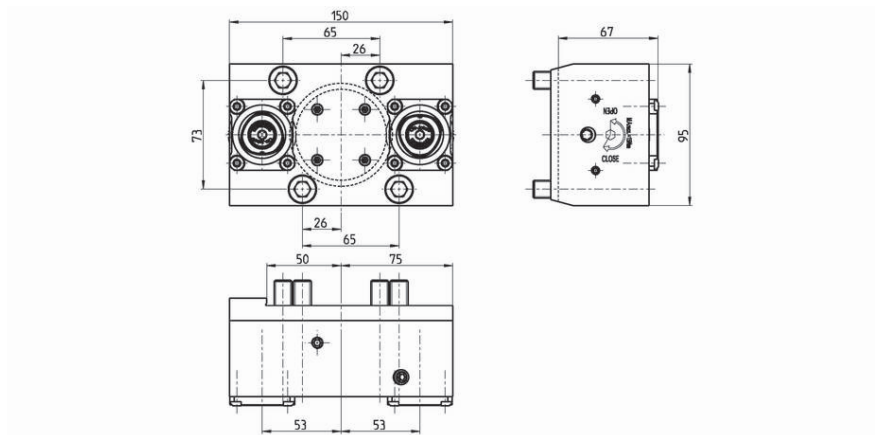

(A) Feststehende Werkzeughalter Fixed tool holder

EPPINGER PSC
EPPINGER PSC

Werkzeughalter, abgewinkelt Schnellwechselsystem, EPPINGER PSC 40, LH Kühlmittel extern und zentral
Tool holder, angular quick change, EPPINGER PSC 40, LH external and central coolant supply

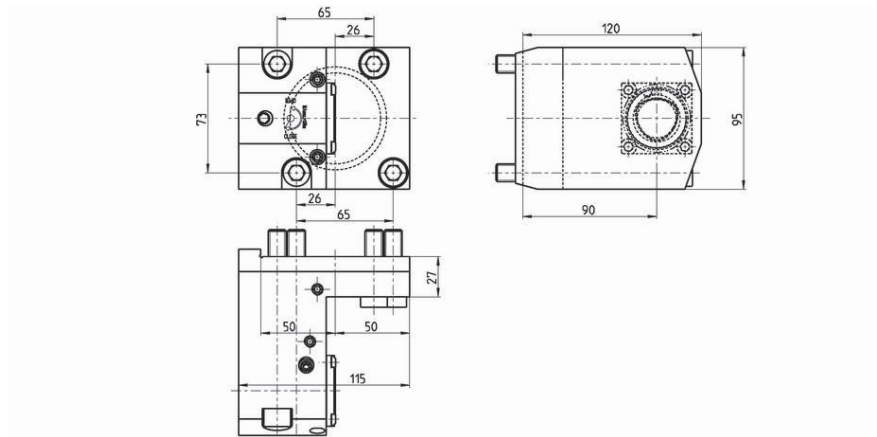
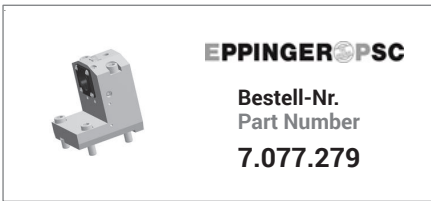

Werkzeughalter, abgewinkelt Schnellwechselsystem, EPPINGER PSC 40, RH Kühlmittel extern und zentral
Tool holder, angular quick change, EPPINGER PSC 40, RH external and central coolant supply

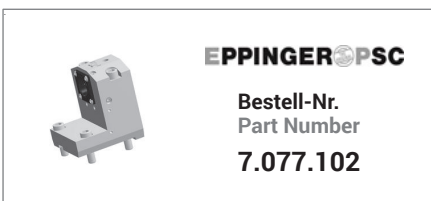

Zubehör Accessories

Rohrverschraubung 0.000.377

Coolant tubes 0.000.377

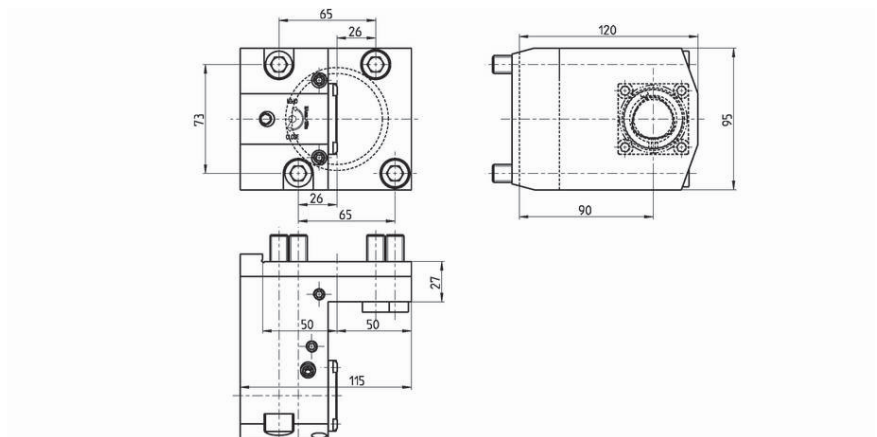

(A) Feststehende Werkzeughalter Fixed tool holder

EPPINGER PSC
EPPINGER PSC

Werkzeughalter, abgewinkelt Schnellwechselsystem, EPPINGER PSC 40, RH Kühlmittel extern und zentral
Tool holder, angular quick change, EPPINGER PSC 40, RH external and central coolant supply

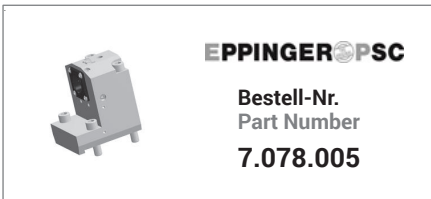

Zubehör
Accessories

Rohrverschraubung 0.000.377

Coolant tubes 0.000.377

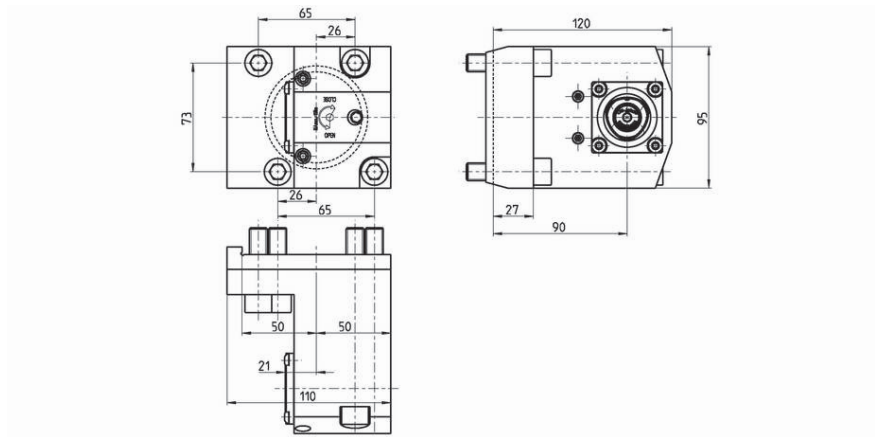

Werkzeughalter, abgewinkelt Schnellwechselsystem, EPPINGER PSC 40, LH Kühlmittel extern und zentral
Tool holder, angular quick change, EPPINGER PSC 40, LH external and central coolant supply

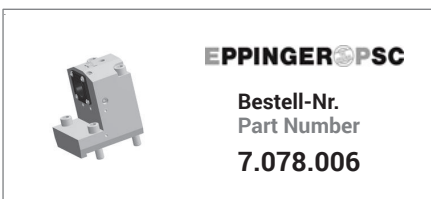

Zubehör
Accessories

Rohrverschraubung 0.000.377

Coolant tubes 0.000.377

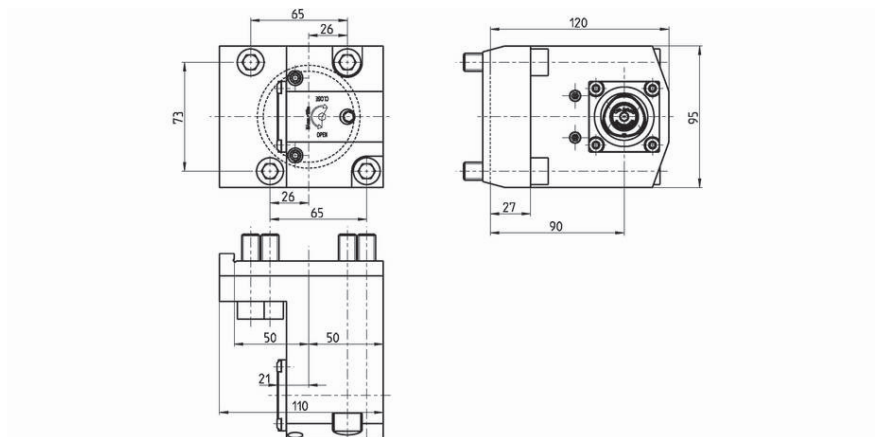

(A) Feststehende Werkzeughalter Fixed tool holder

EPPINGER PSC
EPPINGER PSC

Werkzeughalter, abgewinkelt Schnellwechselsystem, EPPINGER PSC 40, RH Kühlmittel extern und zentral
Tool holder, angular quick change, EPPINGER PSC 40, RH external and central coolant supply

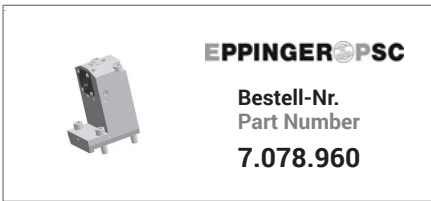

Zubehör
Accessories

Rohrverschraubung 0.000.377

Coolant tubes 0.000.377

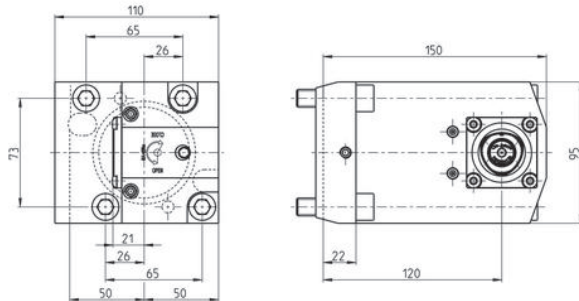

Werkzeughalter, abgewinkelt Schnellwechselsystem, EPPINGER PSC 40, LH Kühlmittel extern und zentral
Tool holder, angular quick change, EPPINGER PSC 40, LH external and central coolant supply

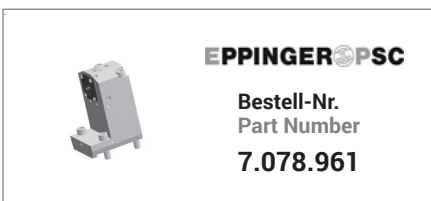

Zubehör
Accessories

Rohrverschraubung 0.000.377

Coolant tubes 0.000.377

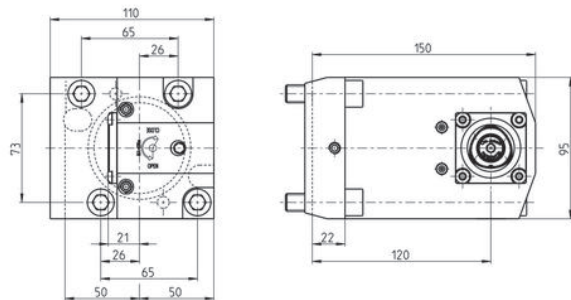

(A) Feststehende Werkzeughalter Fixed tool holder

EPPINGER PSC
EPPINGER PSC

Werkzeughalter, abgewinkelt, mehrfach Schnellwechselsystem, EPPINGER PSC 40, RH Kühlmittel extern und zentral
Tool holder, angular, multiple quick change, EPPINGER PSC 40, RH external and central coolant supply

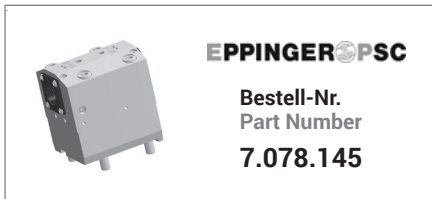

Zubehör
Accessories

Rohrverschraubung 0.000.377

Coolant tubes 0.000.377

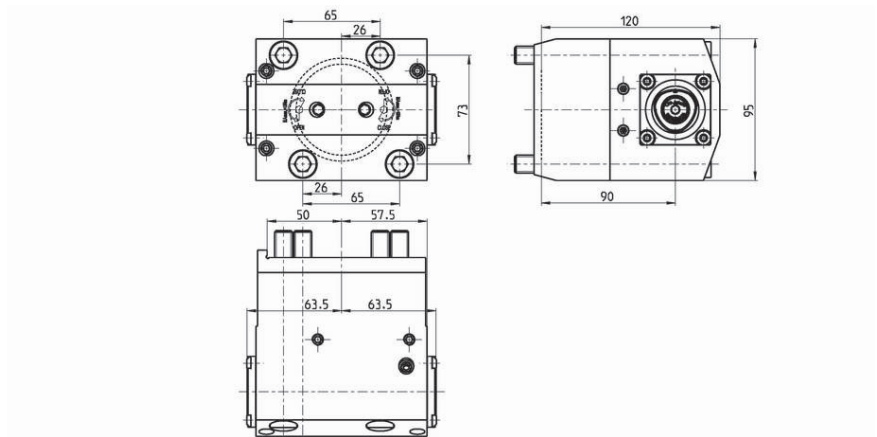

Werkzeughalter, abgewinkelt, mehrfach Schnellwechselsystem, EPPINGER PSC 40, LH Kühlmittel extern und zentral
Tool holder, angular, multiple quick change, EPPINGER PSC 40, LH external and central coolant supply

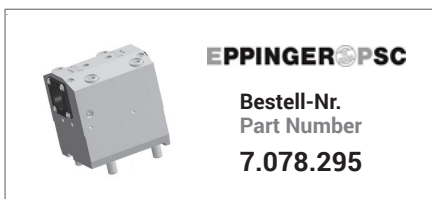

Zubehör
Accessories

Rohrverschraubung 0.000.377

Coolant tubes 0.000.377

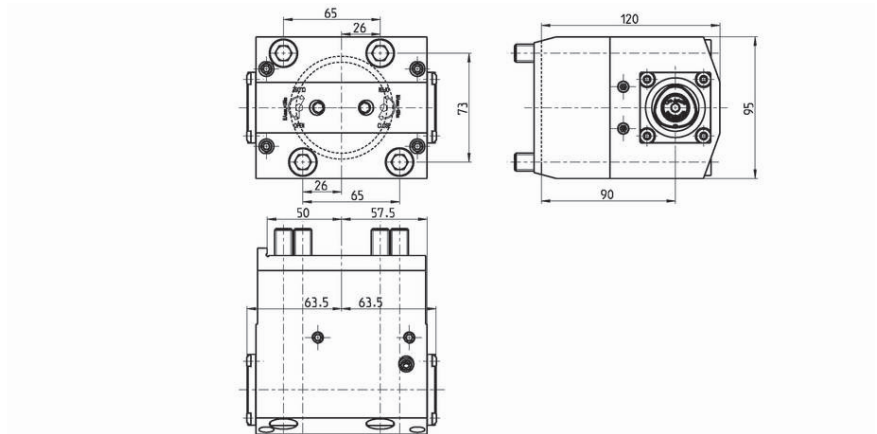

(A) Feststehende Werkzeughalter Fixed tool holder

EPPINGER PSC
EPPINGER PSC

Werkzeughalter, abgewinkelt, mehrfach Schnellwechselsystem, EPPINGER PSC 40, RH Kühlmittel extern und zentral
Tool holder, angular, multiple quick change, EPPINGER PSC 40, RH external and central coolant supply

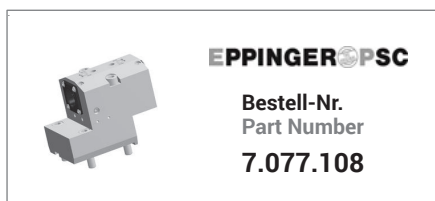

Zubehör Accessories

Rohrverschraubung 0.000.377

Coolant tubes 0.000.377

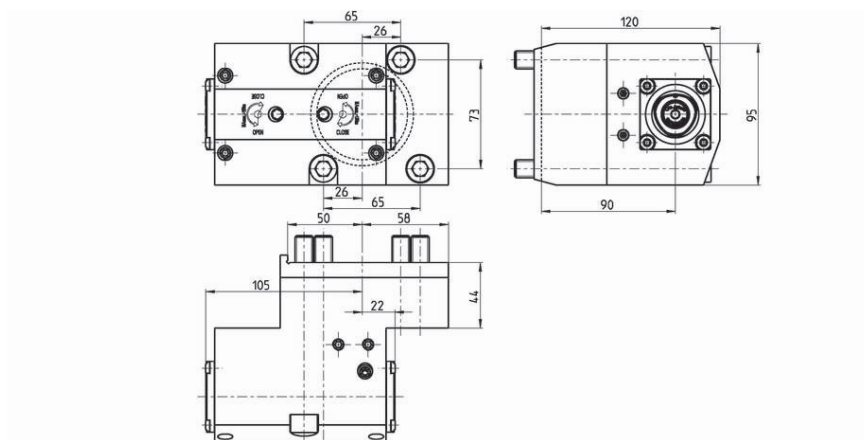

Sonstige Eigenschaften other features

Schutzstopfen Blanking plug

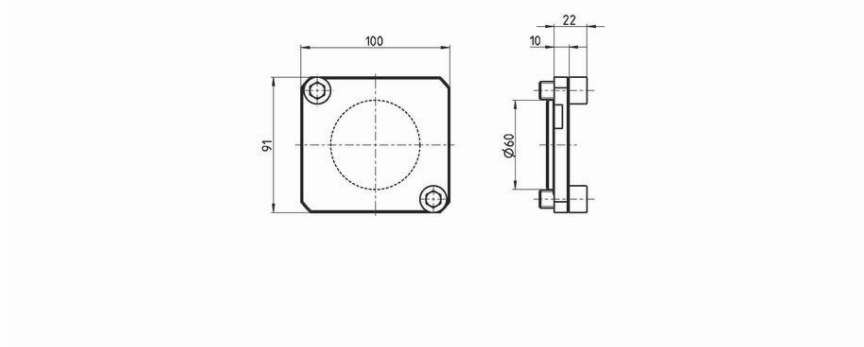
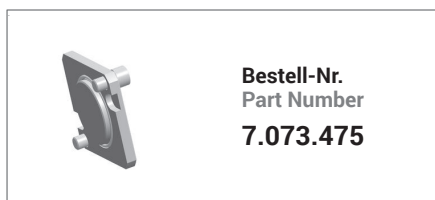

(A) Feststehende Werkzeughalter Fixed tool holder

Sonstige Eigenschaften
other features

Bohrstangenhalter Rohling
Boring bar holder Pre-machined blank

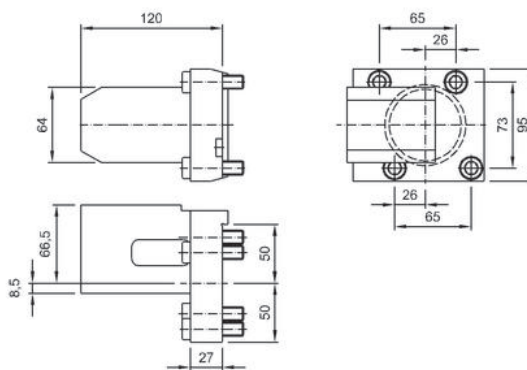
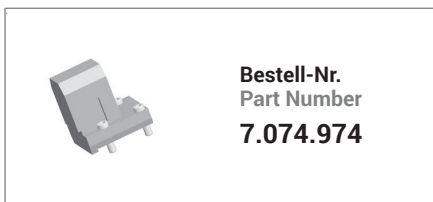

(B) Angetriebene Werkzeughalter Rotary tool holder

Spannzange / PRECI-FLEX®
Collet chuck / PRECI-FLEX®

Bohr- Fräskopf, gerade Spannzangenaufnahme, ER32A, PRECI-FLEX®, Kühlmittel extern
Drilling and milling head, straight collet chuck, ER32A, PRECI-FLEX®, external coolant supply



Übersetzung
Ratio **1:1**
Eingangsdrehzahl
rpm at Input **max. 6000 1/min**
Ausgangsdrehzahl
rpm at Output **max. 6000 1/min**
Ausgangsdrehmoment
Torque as Output **max. 70 Nm**
Drehrichtung
Direction of Rotation

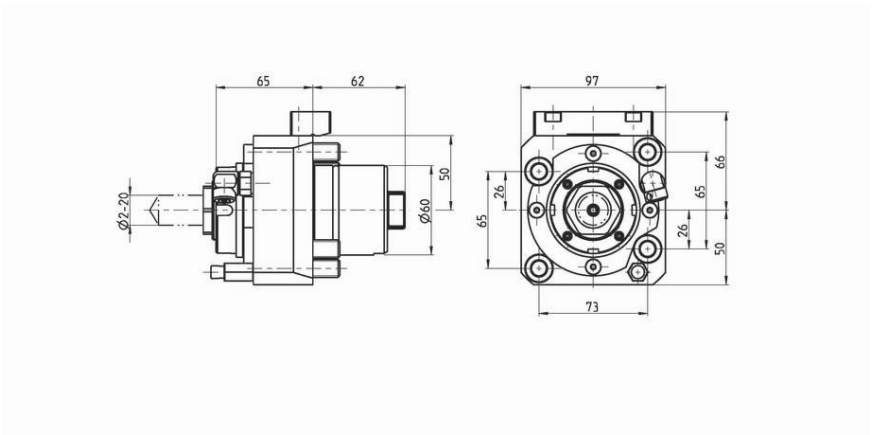

Bohr- Fräskopf, gerade Spannzangenaufnahme, ER32A, PRECI-FLEX® Kühlmittel extern und zentral
Drilling and milling head, straight collet chuck, ER32A, PRECI-FLEX® external and central coolant supply



Übersetzung
Ratio **1:1**
Eingangsdrehzahl
rpm at Input **max. 6000 1/min**
Ausgangsdrehzahl
rpm at Output **max. 6000 1/min**
Ausgangsdrehmoment
Torque as Output **max. 70 Nm**
Drehrichtung
Direction of Rotation

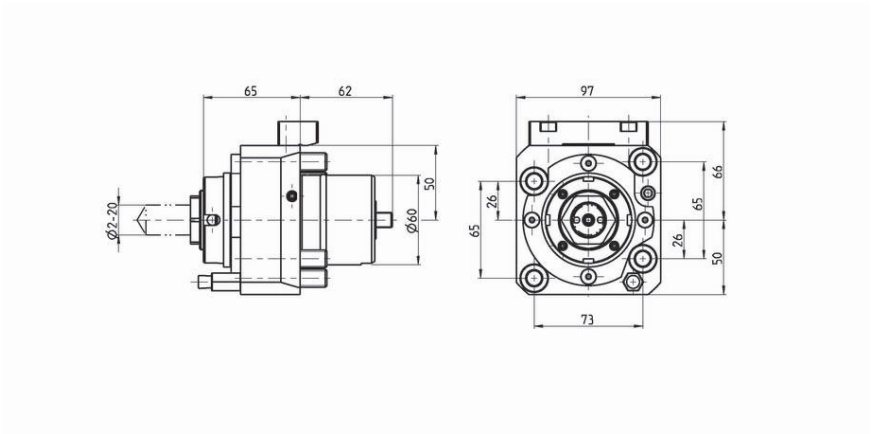

(B) Angetriebene Werkzeughalter Rotary tool holder

Spannzange
Collet chuck

Bohr- Fräskopf, gerade Spannzangenaufnahme, ER32A, PRECI-FLEX®, CC, Hochdruck Kühlmittel zentral
Drilling and milling head, straight collet chuck, ER32A, PRECI-FLEX®, CC, high pressure central coolant supply

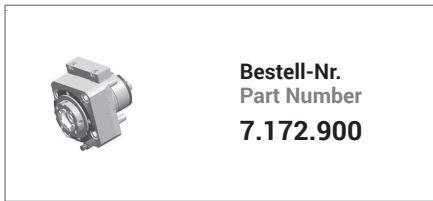

Bestell-Nr.
Part Number
7.172.900

Übersetzung
Ratio **1:1**
Eingangsdrehzahl
rpm at Input **max. 6000 1/min**
Ausgangsdrehzahl
rpm at Output **max. 6000 1/min**
Ausgangsdrehmoment
Torque as Output **max. 70 Nm**
Drehrichtung
Direction of Rotation

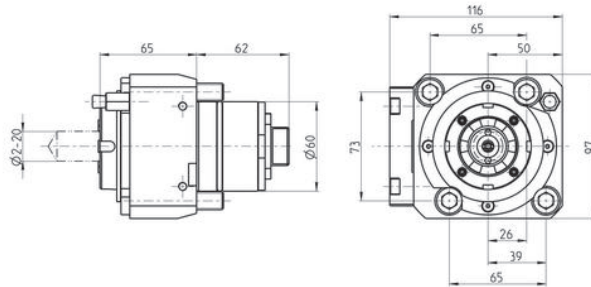

Spannzange / PRECI-FLEX®
Collet chuck / PRECI-FLEX®

Bohr- Fräskopf, gerade, doppelt Spannzangenaufnahme, ER20A, PRECI-FLEX® Kühlmittel extern Ausrichtung zur Hauptspindel
Drilling and milling head, straight, double collet chuck, ER20A, PRECI-FLEX® external coolant supply



PRECI-FLEX®

Bestell-Nr.
Part Number
7.073.450

Übersetzung
Ratio **1:1,368**
Eingangsdrehzahl
rpm at Input **max. 6000 1/min**
Ausgangsdrehzahl
rpm at Output **max. 8210 1/min**
Ausgangsdrehmoment
Torque as Output **max. 50 Nm**
Drehrichtung
Direction of Rotation

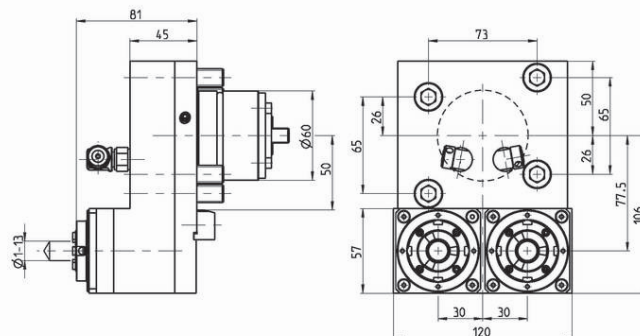

(B) Angetriebene Werkzeughalter Rotary tool holder

Spannzange / PRECI-FLEX®
Collet chuck / PRECI-FLEX®

Bohr- Fräskopf, gerade, doppelt Spannzangenaufnahme, ER20A, PRECI-FLEX® Kühlmittel extern und zentral
Drilling and milling head, straight, double collet chuck, ER20A, PRECI-FLEX® external and central coolant supply



Übersetzung
Ratio **1:1,368**
Eingangsdrehzahl
rpm at Input **max. 6000 1/min**
Ausgangsdrehzahl
rpm at Output **max. 8210 1/min**
Ausgangsdrehmoment
Torque as Output **max. 50 Nm**
Drehrichtung
Direction of Rotation

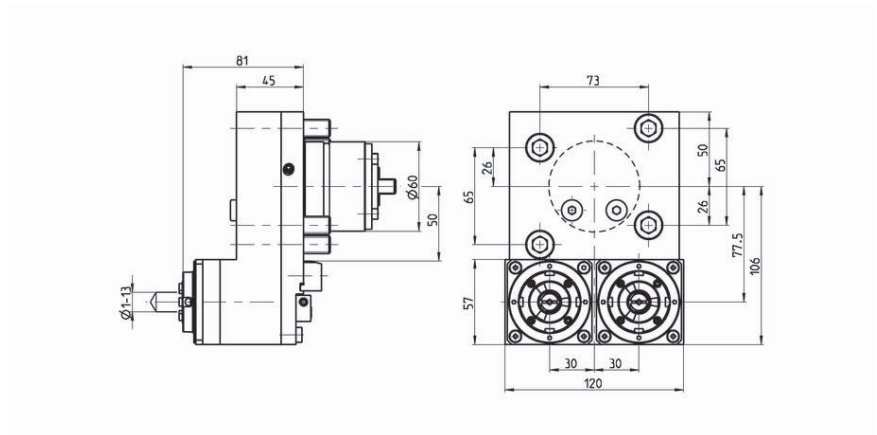

Bohr- Fräskopf, gerade, doppelt Spannzangenaufnahme, ER20A, PRECI-FLEX® Kühlmittel extern Ausrichtung in Haupt- und Gegenspindel
Drilling and milling head, straight, double collet chuck, ER20A, PRECI-FLEX® external coolant supply



Übersetzung
Ratio **1:1,368**
Eingangsdrehzahl
rpm at Input **max. 6000 1/min**
Ausgangsdrehzahl
rpm at Output **max. 8210 1/min**
Ausgangsdrehmoment
Torque as Output **max. 50 Nm**
Drehrichtung
Direction of Rotation

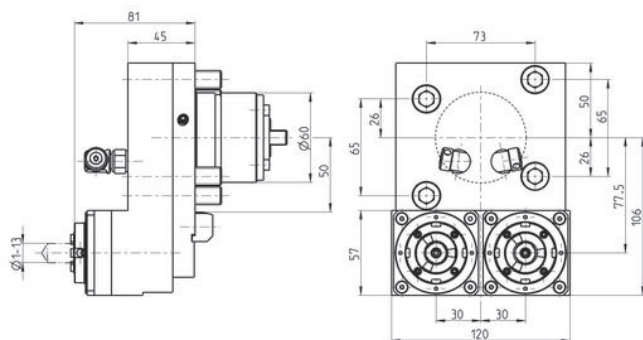

(B) Angetriebene Werkzeughalter Rotary tool holder

Spannzange / PRECI-FLEX®
Collet chuck / PRECI-FLEX®

Bohr- Fräskopf, abgewinkelt, links-rechts Spannzangenaufnahme, ER32A, PRECI-FLEX®, Kühlmittel extern
Drilling and milling head, angular, left hand - right hand collet chuck, ER32A, PRECI-FLEX®, external coolant supply



Übersetzung
Ratio **1:1**
Eingangsdrehzahl
rpm at Input **max. 6000 1/min**
Ausgangsdrehzahl
rpm at Output **max. 6000 1/min**
Ausgangsdrehmoment
Torque as Output **max. 70 Nm**
Drehrichtung
Direction of Rotation

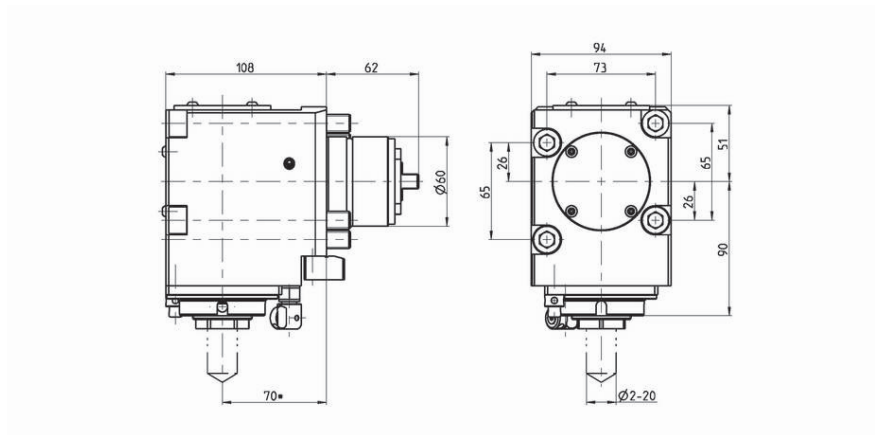

Bohr- Fräskopf, abgewinkelt, doppelseitig Spannzangenaufnahme, ER32A, PRECI-FLEX®, Kühlmittel extern
Drilling and milling head, angular, double sided collet chuck, ER32A, PRECI-FLEX®, external coolant supply



Übersetzung
Ratio **1:1**
Eingangsdrehzahl
rpm at Input **max. 6000 1/min**
Ausgangsdrehzahl
rpm at Output **max. 6000 1/min**
Ausgangsdrehmoment
Torque as Output **max. 70 Nm**
Drehrichtung
Direction of Rotation

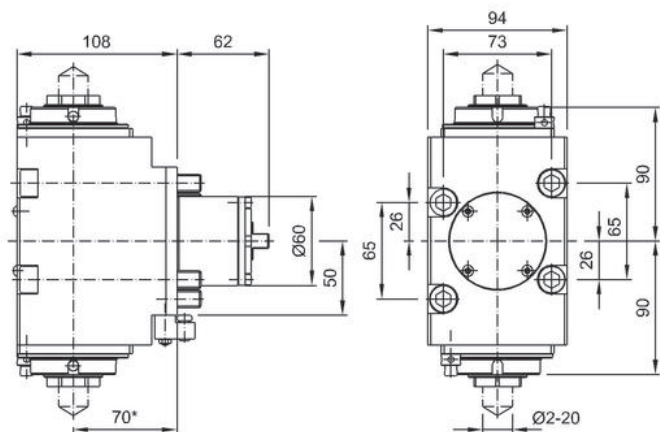

(B) Angetriebene Werkzeughalter Rotary tool holder

Spannzange / PRECI-FLEX®
Collet chuck / PRECI-FLEX®

Bohr- Fräskopf, abgewinkelt, links, kurz Spannzangenaufnahme, ER25A, PRECI-FLEX®, Kühlmittel extern
Drilling and milling head, angular, left hand, short collet chuck, ER25A, PRECI-FLEX®, external coolant supply



Übersetzung
Ratio **1:3**
Eingangsdrehzahl
rpm at Input **max. 6000 1/min**
Ausgangsdrehzahl
rpm at Output **max. 18000 1/min**
Ausgangsdrehmoment
Torque as Output **max. 25 Nm**
Drehrichtung
Direction of Rotation

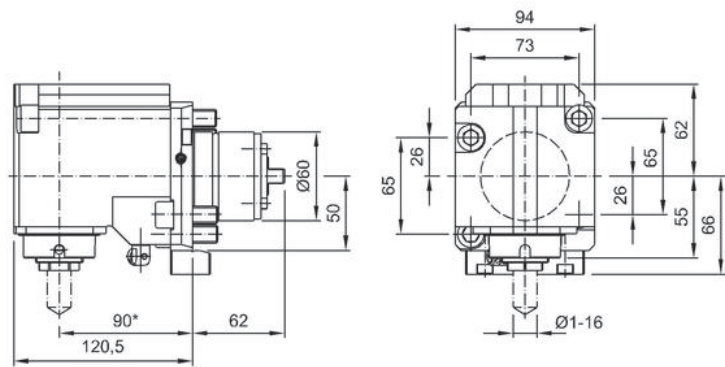

Bohr- Fräskopf, abgewinkelt, doppelseitig Spannzangenaufnahme, ER32A, PRECI-FLEX® Kühlmittel extern und zentral
Drilling and milling head, angular, double sided collet chuck, ER32A, PRECI-FLEX external and central coolant supply



Übersetzung
Ratio **1:1**
Eingangsdrehzahl
rpm at Input **max. 5000 1/min**
Ausgangsdrehzahl
rpm at Output **max. 5000 1/min**
Ausgangsdrehmoment
Torque as Output **max. 100 Nm**

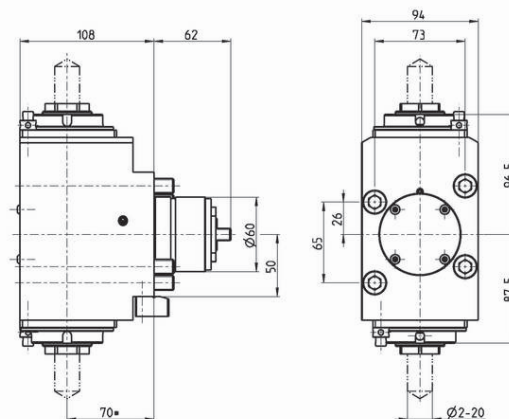

(B) Angetriebene Werkzeughalter Rotary tool holder

EPPINGER PSC
EPPINGER PSC

Bohr- Fräskopf, abgewinkelt, doppelseitig Schnellwechselsystem, EPPINGER PSC 40 Kühlmittel extern
Drilling and milling head, straight, angular, left hand - right hand quick change, EPPINGER PSC 40 external coolant supply



EPPINGER PSC

Bestell-Nr.
Part Number
7.173.245

Übersetzung
Ratio **1:1**
Eingangsdrehzahl
rpm at Input **max. 6000 1/min**
Ausgangsdrehzahl
rpm at Output **max. 6000 1/min**
Ausgangsdrehmoment
Torque as Output **max. 70 Nm**
Drehrichtung
Direction of Rotation

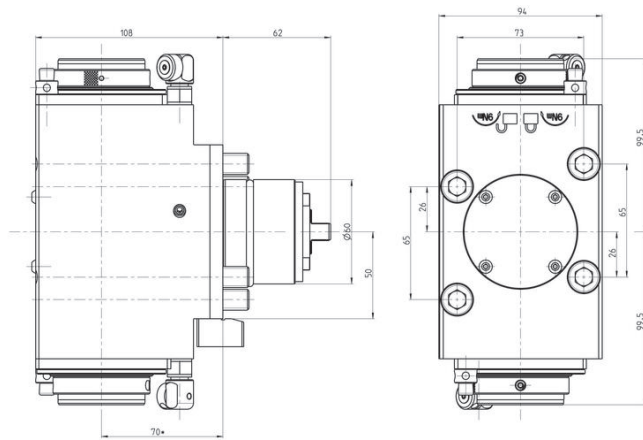

Spannzange / PRECI-FLEX®
Collet chuck / PRECI-FLEX®

Bohr- Fräskopf, abgewinkelt, links-rechts Spannzangenaufnahme, ER32A, PRECI-FLEX® Kühlmittel extern und zentral
Drilling and milling head, angular, left hand - right hand collet chuck, ER32A, PRECI-FLEX® external and central coolant supply



PRECI-FLEX®

Bestell-Nr.
Part Number
7.073.180

Übersetzung
Ratio **1:1**
Eingangsdrehzahl
rpm at Input **max. 6000 1/min**
Ausgangsdrehzahl
rpm at Output **max. 6000 1/min**
Ausgangsdrehmoment
Torque as Output **max. 70 Nm**
Drehrichtung
Direction of Rotation

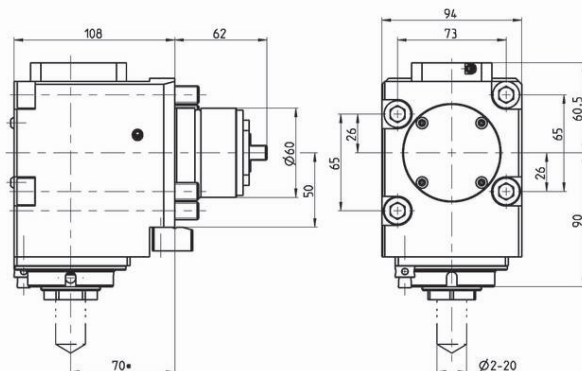

(B) Angetriebene Werkzeughalter Rotary tool holder

Spannzange / PRECI-FLEX®
Collet chuck / PRECI-FLEX®

Bohr- Fräskopf, abgewinkelt, links-rechts Spannzangenaufnahme, ER32A, PRECI-FLEX®, Hochdruck Kühlmittel extern und zentral
Drilling and milling head, angular, left hand - right hand collet chuck, ER32A, PRECI-FLEX®, high pressure external and central coolant supply



Übersetzung
Ratio **1:1**
Eingangsdrehzahl
rpm at Input **max. 6000 1/min**
Ausgangsdrehzahl
rpm at Output **max. 6000 1/min**
Ausgangsdrehmoment
Torque as Output **max. 40 Nm**
Drehrichtung
Direction of Rotation

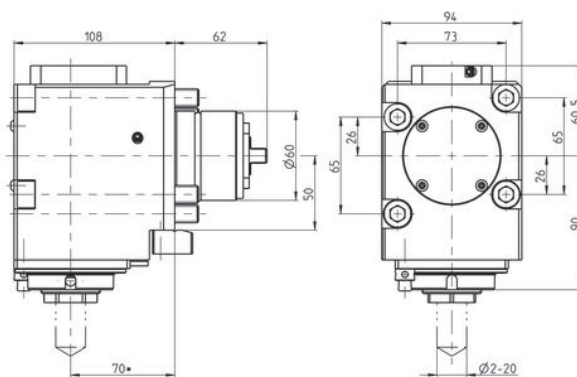

Bohr- Fräskopf, abgewinkelt, doppelt Spannzangenaufnahme, ER20A, PRECI-FLEX® Kühlmittel extern
Drilling and milling head, angular, double sided collet chuck, ER20A, PRECI-FLEX® external coolant supply



Übersetzung
Ratio **1:1,036**
Eingangsdrehzahl
rpm at Input **max. 6000 1/min**
Ausgangsdrehzahl
rpm at Output **max. 6214 1/min**
Ausgangsdrehmoment
Torque as Output **max. 50 Nm**
Drehrichtung
Direction of Rotation

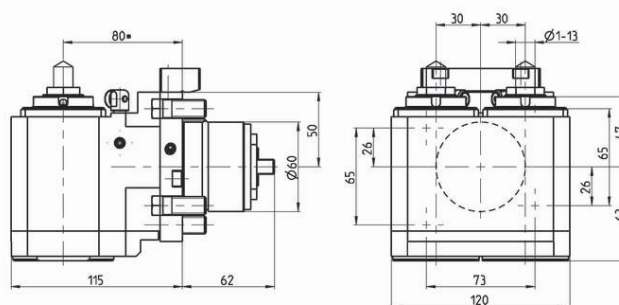

(B) Angetriebene Werkzeughalter Rotary tool holder

Spannzange / PRECI-FLEX®
Collet chuck / PRECI-FLEX®

Bohr- Fräskopf, abgewinkelt, doppelt Spannzangenaufnahme, ER20A, PRECI-FLEX® Kühlmittel extern und zentral
Drilling and milling head, angular, double collet chuck, ER20A, PRECI-FLEX® external and central coolant supply



Übersetzung
Ratio **1:1,036**
Eingangsdrehzahl
rpm at Input **max. 6000 1/min**
Ausgangsdrehzahl
rpm at Output **max. 6214 1/min**
Ausgangsdrehmoment
Torque as Output **max. 50 Nm**
Drehrichtung
Direction of Rotation

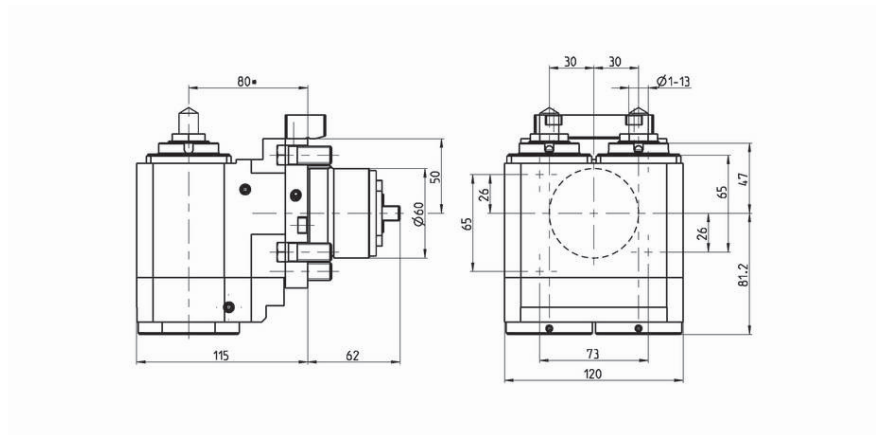

Bohr- Fräskopf, gerade, winkelverstellbar Spannzangenaufnahme, ER20A, PRECI-FLEX®, Kühlmittel extern
Drilling and milling head, straight, angular adjustable collet chuck, ER20A, PRECI-FLEX®, external coolant supply



Übersetzung
Ratio **1:1**
Eingangsdrehzahl
rpm at Input **max. 6000 1/min**
Ausgangsdrehzahl
rpm at Output **max. 6000 1/min**
Ausgangsdrehmoment
Torque as Output **max. 13 Nm**
Drehrichtung
Direction of Rotation

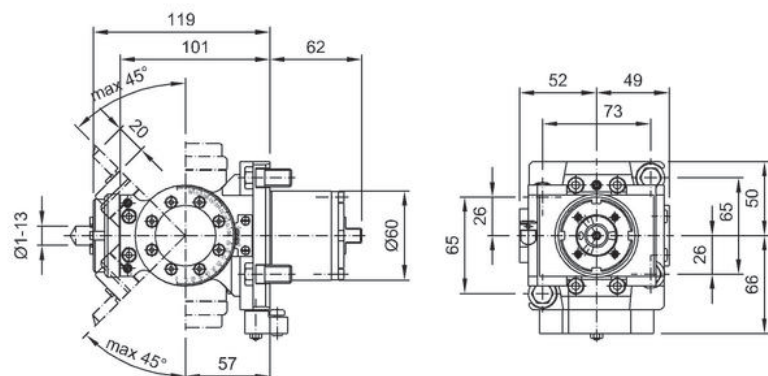

(B) Angetriebene Werkzeughalter Rotary tool holder

EPPINGER PSC
EPPINGER PSC

Bohr- Fräskopf, gerade Schnellwechselsystem, EPPINGER PSC 40 Kühlmittel extern
Drilling and milling head, straight quick change, EPPINGER PSC 40 external coolant supply

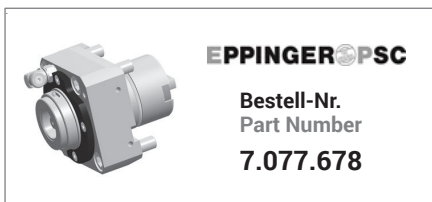

Übersetzung
Ratio **1:1**
Eingangsdrehzahl
rpm at Input **max. 6000 1/min**
Ausgangsdrehzahl
rpm at Output **max. 6000 1/min**
Ausgangsdrehmoment
Torque as Output **max. 70 Nm**
Drehrichtung
Direction of Rotation

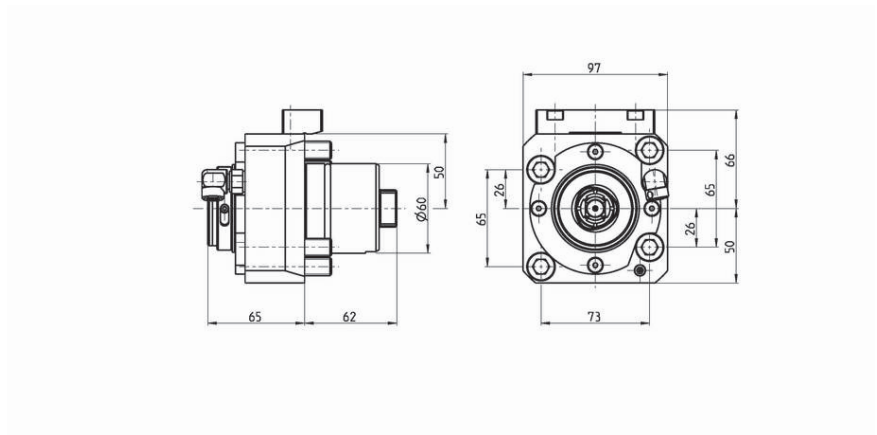

Bohr- Fräskopf, gerade Schnellwechselsystem, EPPINGER PSC 40 Kühlmittel extern und zentral
Drilling and milling head, straight quick change, EPPINGER PSC 40 external and central coolant supply



Übersetzung
Ratio **1:1**
Eingangsdrehzahl
rpm at Input **max. 6000 1/min**
Ausgangsdrehzahl
rpm at Output **max. 6000 1/min**
Ausgangsdrehmoment
Torque as Output **max. 70 Nm**
Drehrichtung
Direction of Rotation

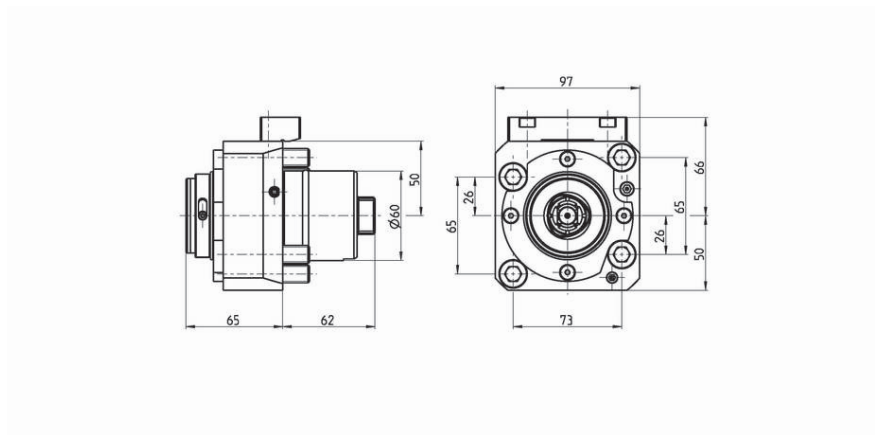

(B) Angetriebene Werkzeughalter Rotary tool holder

EPPINGER PSC
EPPINGER PSC

Bohr- Fräskopf, abgewinkelt, links-rechts Schnellwechselsystem, EPPINGER PSC 40 Kühlmittel extern
Drilling and milling head, straight, angular, left hand - right hand quick change, EPPINGER PSC 40 external coolant supply



Übersetzung
Ratio **1:1**
Eingangsdrehzahl
rpm at Input **max. 6000 1/min**
Ausgangsdrehzahl
rpm at Output **max. 6000 1/min**
Ausgangsdrehmoment
Torque as Output **max. 70 Nm**
Drehrichtung
Direction of Rotation

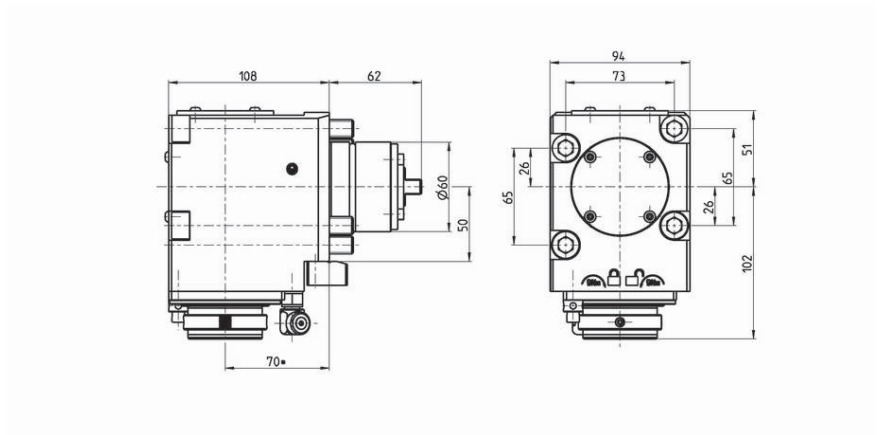

Bohr- Fräskopf, abgewinkelt, links-rechts Schnellwechselsystem, EPPINGER PSC 40 Kühlmittel extern und zentral
Drilling and milling head, angular, left hand - right hand quick change, EPPINGER PSC 40 external and central coolant supply

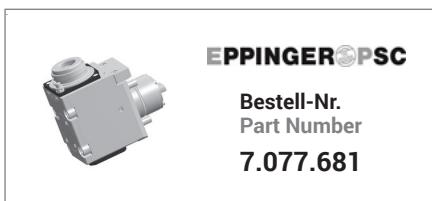

Übersetzung
Ratio **1:1**
Eingangsdrehzahl
rpm at Input **max. 6000 1/min**
Ausgangsdrehzahl
rpm at Output **max. 6000 1/min**
Ausgangsdrehmoment
Torque as Output **max. 70 Nm**
Drehrichtung
Direction of Rotation

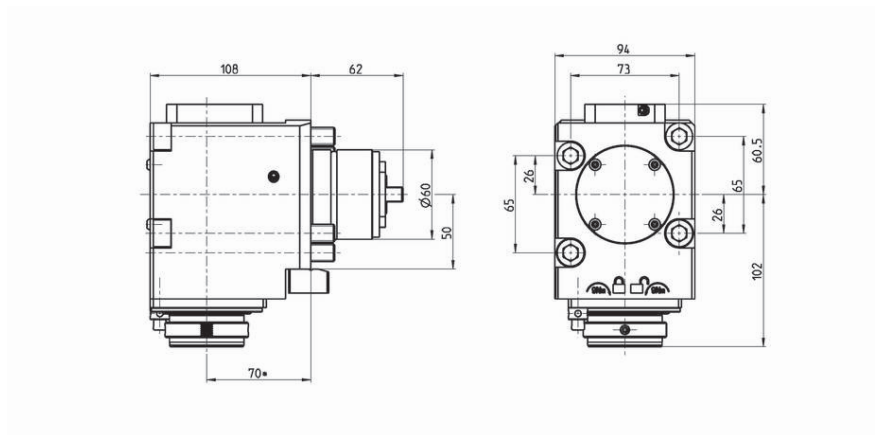

(B) Angetriebene Werkzeughalter Rotary tool holder

Schnellwechselsystem (z.B. : SK, BT, CAT)
Quick change tooling systems

Stosshalter
Shaping Tool Holder



Bestell-Nr.
Part Number
1102981

Übersetzung
Ratio **2:1**
Eingangsdrehzahl
rpm at Input **max. 3000 1/min**
Ausgangsdrehzahl
rpm at Output **max. 1500 1/min**
Ausgangsdrehmoment
Torque as Output **max. 15 Nm**

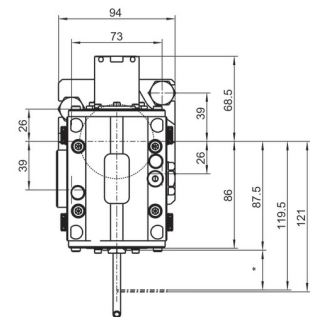
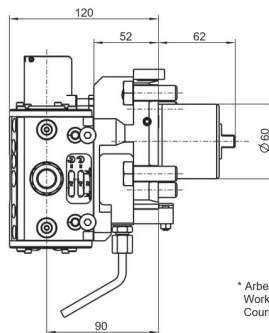

* Arbeitshub
Working stroke
Course de travail

Kreissägen mit Gegenlager
Slotting saws

Kreissägehalter Fräserdornaufnahme Ø22, Kühlmittel extern
Spindle unit for side milling cutters chuck for cutter arbor Ø22, external coolant supply

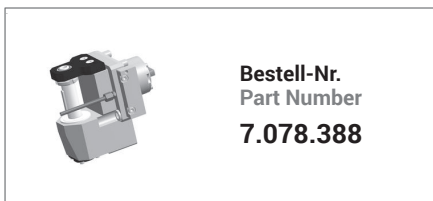

Bestell-Nr.
Part Number
7.078.388

Übersetzung
Ratio **2:1**
Eingangsdrehzahl
rpm at Input **max. 6000 1/min**
Ausgangsdrehzahl
rpm at Output **max. 3000 1/min**
Ausgangsdrehmoment
Torque as Output **max. 45 Nm**
Drehrichtung
Direction of Rotation

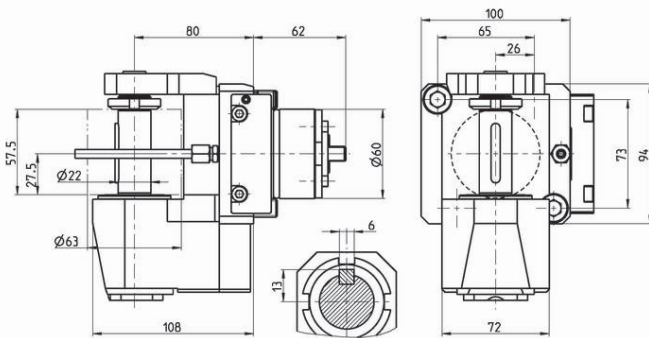

(C) Adapter Adapter

01 Spannzangenaufnahme Collet Chuck



Adapter	Bestell-Nr./Part Number
16 mm	2001-0089
16 mm	2501-0080
20 mm	2001-0090
20 mm	2501-0349
25 mm	2501-0081
25 mm	3201-0026
25 mm	3201-1034
32 mm	3201-0027

02 Spannzangenaufnahme lang Collet Chuck extended



Adapter	Bestell-Nr./Part Number
8 mm	2002-0944
11 mm	2002-0092
11 mm	2002-0666
11 mm	2502-0082
11 mm	2502-0419
16 mm	2002-0549
16 mm	2002-0550
16 mm	2502-0498
16 mm	2502-1056
16 mm	2502-1163
16 mm	3202-0025
16 mm	3202-0397
20 mm	3202-1204

03 Weldon kurz Weldon short



Adapter	Bestell-Nr./Part Number
4 mm	2003-0401
5 mm	2503-1118
5 mm	3203-0274
6 mm	2003-0094
6 mm	2003-0344
6 mm	2503-0056
6 mm	2503-0061
6 mm	3203-0001
6 mm	3203-0336
1/4"	2003-0097
1/4"	2503-0099
1/4"	3203-0103
8 mm	2003-0095
8 mm	2003-0345
8 mm	2503-0057
8 mm	3203-0002
8 mm	3203-0337
3/8"	2003-0098
3/8"	2503-0100
3/8"	3203-0104
10 mm	2003-0096
10 mm	2003-0346
10 mm	2503-0058
10 mm	3203-0003
10 mm	3203-0338
11 mm	3203-0446
12 mm	2003-0150
12 mm	2003-0347
12 mm	2503-0059
12 mm	2503-0062
12 mm	3203-0004
12 mm	3203-0339
1/2"	2003-0151
1/2"	2503-0101
1/2"	3203-0105
14 mm	2503-0278
14 mm	3203-0275
14 mm	3203-0340
5/8"	2503-0102
5/8"	3203-0106
16 mm	2503-0060
16 mm	2503-0063
16 mm	3203-0005
16 mm	3203-0341
18 mm	3203-0321
18 mm	3203-0342
3/4"	3203-0107

Adapter	Bestell-Nr./Part Number
20 mm	3203-0033
20 mm	3203-0343

04 Weldon lang Weldon extended



Adapter	Bestell-Nr./Part Number
4 mm	2504-0667
6 mm	2004-0181
6 mm	2504-0061
6 mm	3204-0006
6 mm	3204-0398
6 mm	3204-1062
1/4"	2004-0185
1/4"	2504-0188
1/4"	3204-0192
8 mm	2004-0182
8 mm	2504-0062
8 mm	3204-0007
8 mm	3204-0399
8 mm	3204-1063
3/8"	2004-0186
3/8"	2504-0189
3/8"	3204-0193
3/8"	3204-0196
10 mm	2004-0183
10 mm	2504-0063
10 mm	2504-0546
10 mm	3204-0008
10 mm	3204-0400
10 mm	3204-1064
12 mm	2004-0184
12 mm	2504-0064
12 mm	2504-0547
12 mm	3204-0009
1/2"	2004-0187
1/2"	2504-0190
1/2"	3204-0194
14 mm	2004-0320
14 mm	2504-0325
14 mm	3204-0499
5/8"	2004-0700
5/8"	2504-0191
5/8"	3204-0195
16 mm	2004-0332
16 mm	2504-0065
16 mm	2504-0548
16 mm	3204-0010

(C) Adapter Adapter

Adapter	Bestell-Nr./Part Number
18 mm	2504-0300
18 mm	3204-0453
3/4"	2504-0323
20 mm	2504-0301
20 mm	3204-0034
25 mm	2504-0445
25 mm	3204-0279
25 mm	3204-0656
1"	3204-0409

05 Whistle Notch kurz Whistle Notch short



Adapter	Bestell-Nr./Part Number
5 mm	3205-0283
6 mm	2005-0121
6 mm	2505-0066
6 mm	3205-0044
6 mm	3205-0134
1/4"	2005-0124
1/4"	2505-0126
1/4"	3205-0130
8 mm	2005-0122
8 mm	2505-0067
8 mm	3205-0045
3/8"	2005-0125
3/8"	2505-0127
3/8"	3205-0131
10 mm	2005-0123
10 mm	2505-0068
10 mm	3205-0046
12 mm	2005-0148
12 mm	2505-0069
12 mm	3205-0047
1/2"	2005-0149
1/2"	2505-0128
1/2"	3205-0132
14 mm	2505-0282
5/8"	2505-0129
5/8"	3205-0133
16 mm	2505-0070
16 mm	3205-0048
18 mm	3205-0329
3/4"	3205-0281
20 mm	3205-0049

06 Whistle Notch lang Whistle Notch extended



Adapter	Bestell-Nr./Part Number
6 mm	2006-0152
6 mm	2506-0071
6 mm	3206-0050
1/4"	2006-0156
1/4"	2506-0159
1/4"	3206-0163
8 mm	2006-0153
8 mm	2506-0072
8 mm	3206-0051
3/8"	2006-0157
3/8"	2506-0160
3/8"	3206-0164
10 mm	2006-0154
10 mm	2506-0073
10 mm	3206-0052
12 mm	2006-0155
12 mm	2506-0074
12 mm	3206-0053
1/2"	2006-0158
1/2"	2506-0161
1/2"	3206-0165
14 mm	2006-0328
14 mm	2506-0326
14 mm	3206-0410
5/8"	2006-0701
5/8"	2506-0162
5/8"	3206-0166
16 mm	2506-0075
16 mm	3206-0054
18 mm	2506-0327
18 mm	3206-0451
3/4"	2506-0324
3/4"	3206-0167
20 mm	2506-0322
20 mm	3206-0055
25 mm	3206-0280

07 Fräsdorn Milling Arbor



Adapter	Bestell-Nr./Part Number
1/2"	2007-0235
1/2"	2507-0236
1/2"	3207-0240
13 mm	2507-0317
14 mm	2007-1091
16 mm	2007-0234
16 mm	2007-0962
16 mm	2507-0083
16 mm	2507-0394
16 mm	3207-0023
16 mm	3207-1067
3/4"	2507-0262
3/4"	3207-0237
22 mm	2007-0412
22 mm	2507-0084
22 mm	2507-0596
22 mm	2507-0669
22 mm	3207-0024
22 mm	3207-0420
22 mm	3207-1068
22 mm	3207-1155
27 mm	2507-0395
27 mm	3207-0318
27 mm	3207-0331
32 mm	2507-0406
32 mm	3207-0585

08 Bohrstangenaufnahme Adaptor for Boring Bars



Adapter	Bestell-Nr./Part Number
6 mm	2008-0217
6 mm	2508-0335
6 mm	3208-0396
1/4"	2008-0221
8 mm	2008-0218
8 mm	2508-0076

(C) Adapter Adapter

Adapter	Bestell-Nr./Part Number
8 mm	3208-0028
3/8"	2008-0222
3/8"	2508-0210
3/8"	3208-0213
10 mm	2008-0219
10 mm	2508-0077
10 mm	3208-0029
12 mm	2008-0220
12 mm	2508-0078
12 mm	3208-0030
1/2"	2008-0223
1/2"	2508-0211
1/2"	3208-0214
14 mm	2008-0333
5/8"	2508-0212
5/8"	3208-0215
16 mm	2008-0334
16 mm	2508-0079
16 mm	2508-0316
16 mm	3208-0031
3/4"	3208-0216
20 mm	3208-0032
22 mm	3208-0431
25 mm	3208-0319

09 Rohling Blank

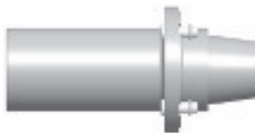

Adapter	Bestell-Nr./Part Number
27 mm	2009-0242
30 mm	2509-0085
38 mm	3209-0012
38 mm	3209-0330
40 mm	2509-0430
50 mm	2509-0975

10 Prüfdorn Test Mandrel



Adapter	Bestell-Nr./Part Number
20 mm	2010-0246
20 mm	2010-0247
20 mm	2510-0086
20 mm	2510-0087
20 mm	3210-0011
20 mm	3210-0088

13 Dehnspannfutter Hydraulic Chuck

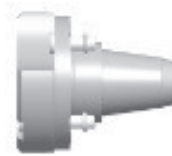

Adapter	Bestell-Nr./Part Number
12 mm	2013-0311
12 mm	2513-0315
12 mm	3213-1196
20 mm	3213-0309

14 Schrumpffutter/Press Fit Shrink Fit/Press Fit



Adapter	Bestell-Nr./Part Number
6 mm	2014-0350
6 mm	2514-0354
6 mm	2514-0513
6 mm	2514-0997
6 mm	3214-0360
1/4"	3214-0382
8 mm	2014-0351

Adapter	Bestell-Nr./Part Number
8 mm	2514-0355
8 mm	2514-0514
8 mm	2514-0998
8 mm	3214-0361
3/8"	3214-0383
10 mm	2014-0352
10 mm	2514-0356
10 mm	2514-0515
10 mm	2514-0999
10 mm	3214-0362
12 mm	2014-0353
12 mm	2514-0357
12 mm	2514-1000
12 mm	3214-0363
14 mm	2514-0358
14 mm	3214-0364
5/8"	3214-0385
16 mm	2514-0359
16 mm	3214-0365
18 mm	3214-0366
20 mm	3214-0367

15 Spannzangenaufnahme kurz Collet Nose short



Adapter	Bestell-Nr./Part Number
11 mm	2015-0403
20 mm	2515-0404
20 mm	3215-0407
20 mm	3215-0589
25 mm	3215-0405

17 Adapter für verschiedene Schnittstellen Adapter for various Interfaces



Adapter	Bestell-Nr./Part Number
05 mm	2517-1147
05 mm	2517-1151

(C) Adapter Adapter

Adapter	Bestell-Nr./Part Number
05 mm	3217-1149
05 mm	3217-1153
6 mm	2017-0893
6 mm	2517-0803
06 mm	2517-1148
06 mm	2517-1152
06 mm	3217-1150
06 mm	3217-1154
8 mm	2017-0894
8 mm	2517-0804
8 mm	2517-1104
08 mm	2517-1128
08 mm	2517-1131
8 mm	3217-0805
8 mm	3217-1113
08 mm	3217-1135
08 mm	3217-1138
10 mm	2017-0895
10 mm	2517-0725
10 mm	2517-1105
10 mm	2517-1129
10 mm	2517-1132
10 mm	3217-0806
10 mm	3217-1114
10 mm	3217-1136
10 mm	3217-1139
12 mm	2017-0896
12 mm	2517-0555
12 mm	2517-1106
12 mm	2517-1130
12 mm	2517-1133
12 mm	3217-0807
12 mm	3217-0992
12 mm	3217-1066
12 mm	3217-1115
12 mm	3217-1137
12 mm	3217-1140
1/2"	3217-0712
15 mm	2017-0444
15 mm	2517-1018
15 mm	2517-1121
15 mm	2517-1182
15 mm	3217-1124
15 mm	3217-1183
16 mm	2517-0552
16 mm	2517-1107
16 mm	3217-0808
16 mm	3217-1116
17 mm	2517-1122
17 mm	3217-1125
19 mm	2517-1123
19 mm	3217-1126
20 mm	2517-0521
20 mm	2517-0580
20 mm	3217-1089

Unsere Werkzeugsysteme Our Tooling Solutions

PRECIFLEX®

Das modulare System von Eppinger eröffnet Ihnen hinsichtlich Präzision, Flexibilität und Wirtschaftlichkeit völlig neue Dimensionen. Seine Schnittstelle basiert auf der bekannten Standard-Spannzangen-Aufnahme.

Eppinger's modular system adds a new dimension to high precision flexibility. The basis of our interface is a universally utilized collet configuration.

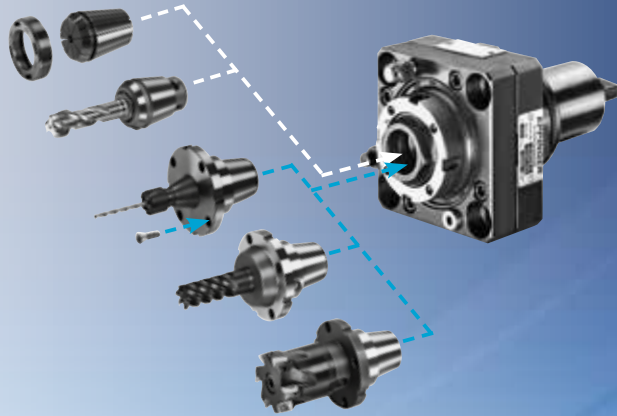

EPPINGER PSC

Zwei Werte bestimmen die Wirtschaftlichkeit eines Werkzeugsystems: kompakte Maße und kurze Rüstzeiten. Bei beiden setzt Eppinger PSC neue Maßstäbe.

Two values define the economics of a tool system. Compact design and speed of setting up. On both items Eppinger has again raised the bar.

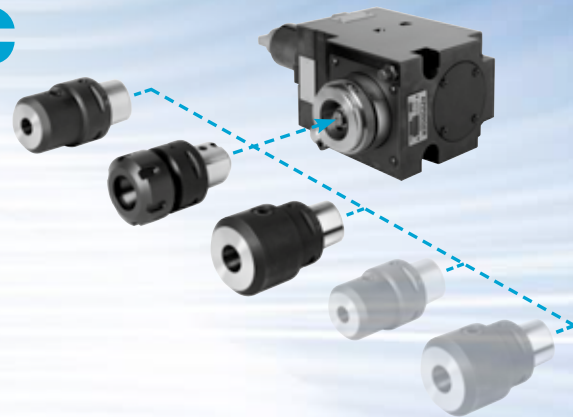

DECOFLEX®

Mit diesem neu entwickelten, überaus kompakten Werkzeugsystem erschließen sich der Zerspanungstechnik völlig neue Möglichkeiten in der Produktion kleiner und kleinster Teile.

With this newly developed, extremely compact tooling system, we are offering new possibilities for the production of your smallest components.

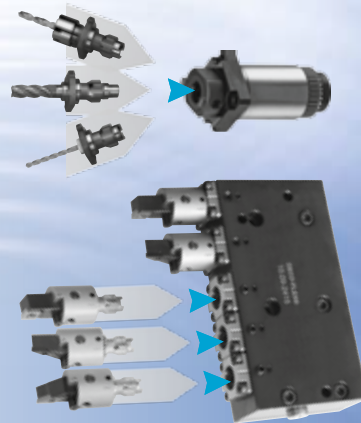

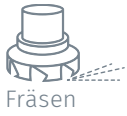

Fräsen



Drehen



Schleifen



Automation

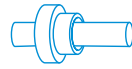

Stangenlader



Service



Zubehör

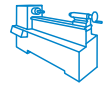

Second Hand



PEHA GmbH Werkzeugmaschinen | Röntgenstraße 6 | 89264 Weißenhorn
Fon: 07309 42952-0 | Fax: 07309 42952-22 | www.peha-center.de | info@peha-center.de