

MU-V Series

MU-5000V

MU-6300V

MU-8000V

5-Axis Vertical Machining Centers

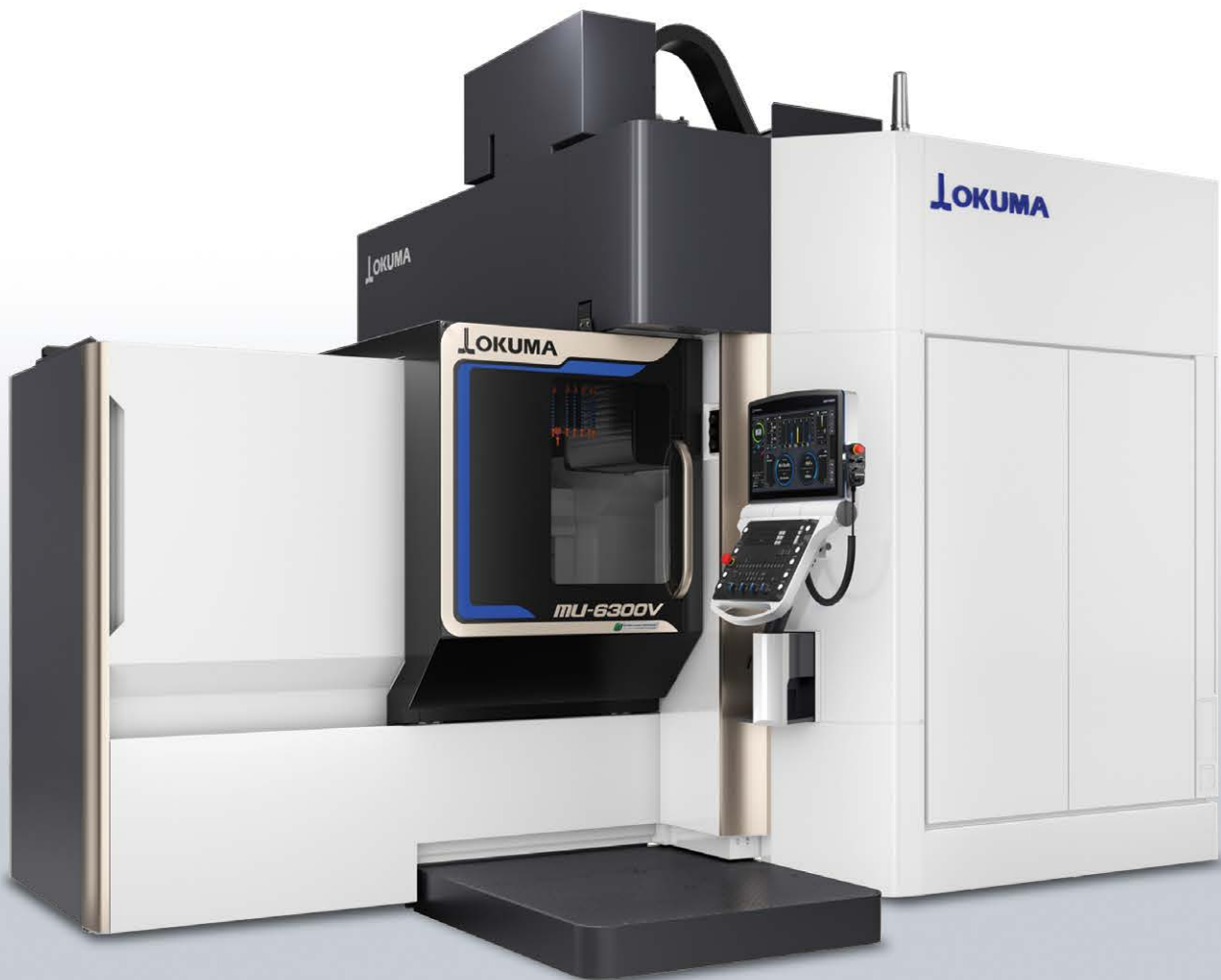

MU-V Series

5-Axis Vertical Machining Centers

MU-5000V / MU-6300V / MU-8000V

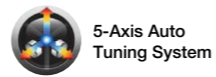
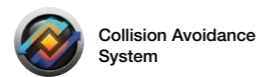

The MU-V series – Changing perceptions of what a 5-axis machine can do

Machining accuracy and capacity similar to 3-axis machines is achieved with a machine design that utilizes “M-E-I-K”*.

The MU-V series combines the above with ease of use and has changed the way people think about 5-axis machines.

Equipped with the next-generation CNC OSP-P500, which facilitates manufacturing DX (digital transformation), this environmentally friendly smart machine reduces power consumption and improves productivity at the same time.

* The merging of Mechanics - Electronics - Information (IT) - Knowledge (Creation) technologies, only Okuma can provide, as Your Single Source for Machine & Control.



MU-5000V



MU-6300V



MU-8000V

Innovations in volumetric accuracy

- Highly rigid trunnion table supports high accuracy and quality
- High accuracy maintained over long times with synergistic effect of Okuma Intelligent Technology

A 5-axis machine that really cuts

- Face milling: 504 cm³/min
- End milling: 672 cm³/min
- Process-intensive machining with turning: 3 mm²

Material: S45C

Note: The “actual data” referred to above for this brochure represent examples, and may not be obtained due to differences in specifications, tooling, cutting condition, and others.

The value of good visibility and operability required in 5-axis machining

- Superb operator access to the machining chamber
- Long travel enables handling of large workpieces
- Tools can be changed even with the trunnion table is tilted

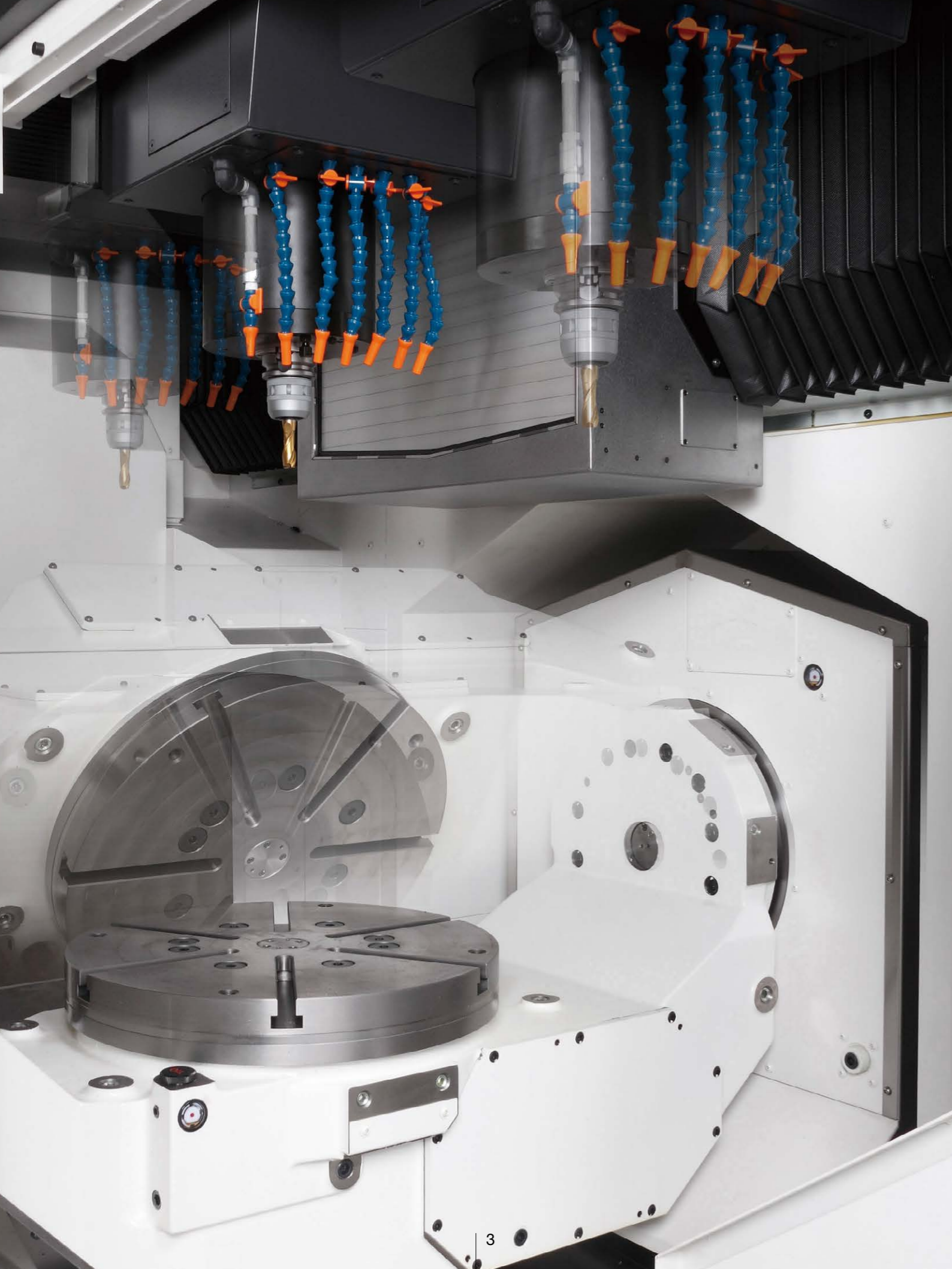

The next-generation 5-axis machining centers further increase the degree of freedom in 5-axis machining with high accuracy and high rigidity as well as large machining space

Highly rigid trunnion table supports high-accuracy 5-axis machining

- Indexing accuracy: 0.7 sec/0.8 sec (A-/C-axis)*
- Indexing return accuracy: 0.4 sec/0.1 sec (A-/C-axis)*
- 90°clamp/unclamp indexing time: 0.1 sec/1.2 sec (A-/C-axis)*
- Highly-rigid trunnion table supports both ends
- With ball-screw cooling (standard), reduced following error is achieved while maintaining highly accurate machining.

* MU-5000V Actual data

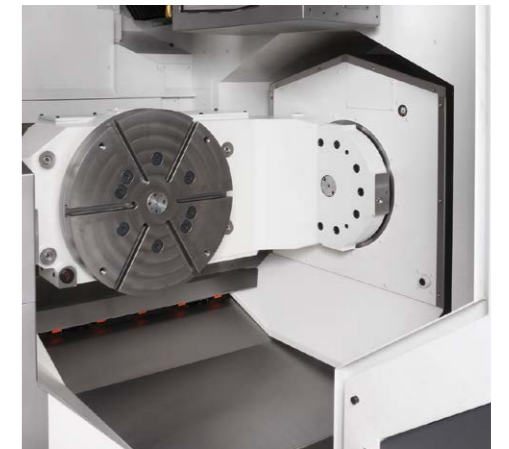

Trunnion table

Large machining range; tools can be changed with trunnion table still in swing position

The tool reaches the end of the workpiece even with the table at various inclination angles, enabling wide-range 5-axis machining. Tool change regardless of trunnion table posture, leading to reduced cycle times and higher machining accuracies.

■ Long travel enables handling of large workpieces

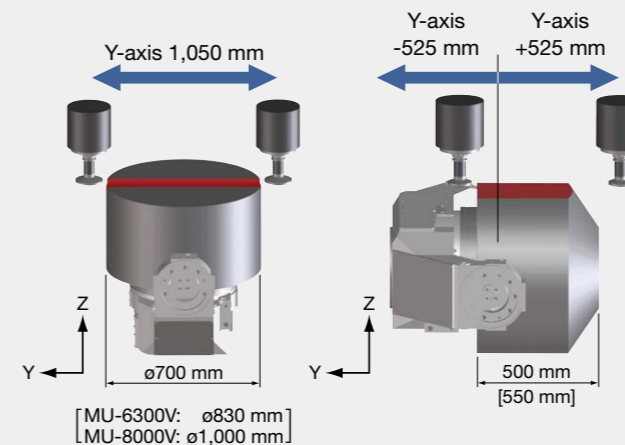

■ Visibility of the cutting edge at the time of cutting also excellent

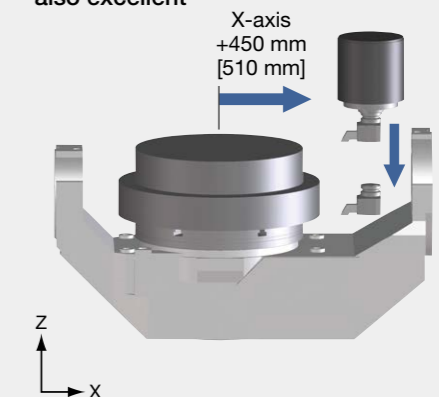

The images are of MU-5000V
[]: MU-6300V, MU-8000V specs



A 5-axis machine that really cuts

Beyond the limits of conventional 5-axis machining Highly efficient machining with amazing machining capacity

Face milling capacity: 504 cm³/min (S45C)

- ø80 face mill 8-blade (coating)
- Spindle speed: 895 min⁻¹
- Cutting speed: 225 m/min
- Feed rate: 2,250 mm/min
- Cut width x infeed: 56 × 4 mm



End milling capacity: 672 cm³/min (S45C)

- ø20 roughing end mill 7-blade (carbide)
- Spindle speed: 4,000 min⁻¹
- Cutting speed: 251 m/min
- Feed rate: 4,800 mm/min [2,800 mm/min]
- Cut width x infeed: 7 × 20 mm [12 × 20 mm]



[]: MU-6300V specs

Note: The "actual data" referred to above for this brochure represent examples, and may not be obtained due to differences in specifications, tooling, cutting condition, and others.

Standard spindle No. 40

- Speed: 10,000 min⁻¹
- Max output: 11/7.5 kW (10 min/cont)
- Max torque: 198/135 N-m (5 min/cont)

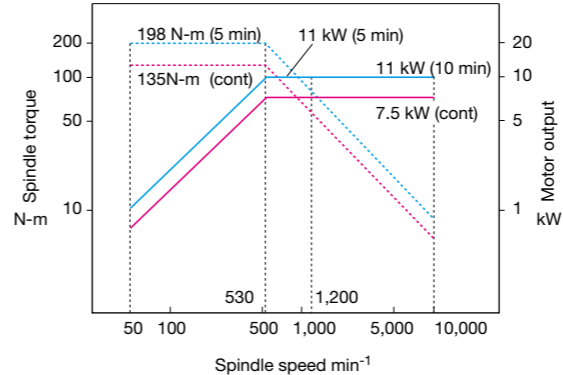

Standard spindle No. 50

- Speed: 6,000 min⁻¹
- Max output: 11/7.5 kW (10 min/cont)
- Max torque: 198/135 N-m (5 min/cont)

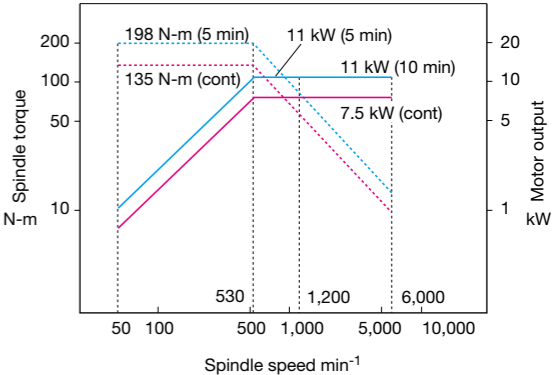

High accuracy 5-axis machining is achieved with advanced technology

Okuma's Intelligent Technology—maximizes machining accuracy

5-Axis Auto Tuning System (option) Gauging and compensation of geometric error

Higher accuracies in 5-axis machining

5-axis machining accuracy is greatly affected by misalignment and other "geometric errors" on the rotary axis. The 5-Axis Auto Tuning System measures geometric error using a touch probe and datum sphere, and performs compensation using measurement results to tune the movement accuracy on 5-axis machines. In this way 5-axis machining accuracy on a higher level is achieved.

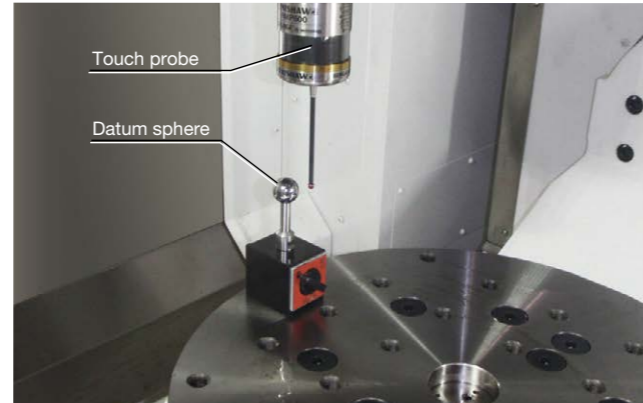
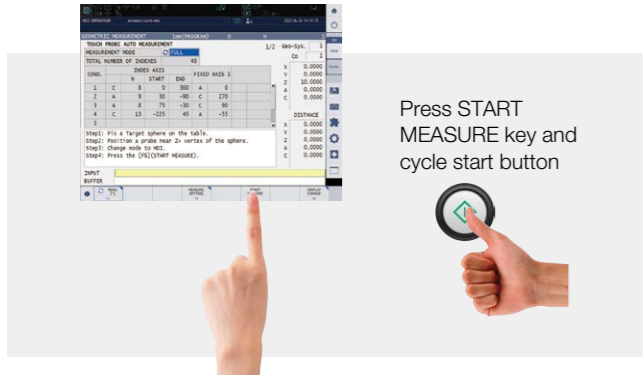

Geometric error measuring and auto tuning performed with a touch probe and a datum sphere

Automatic tuning for geometric error is quick, easy, and can be done by anyone

Previously, manual measurements of the rotating center were bothersome and time-consuming, but with the 5-Axis Auto Tuning System the measurements are made automatically by the machine. Measurements can therefore be done with stable accuracy in a short time by anyone. (Up to 11 geometric errors tuned automatically.) In addition, the results of tuning are applied regardless of whether the operation in auto, manual, or MDI and whether Tool Center Point Control is on or off. Setup and machining can therefore be done with the same operations as before.

[Examples of geometric error]

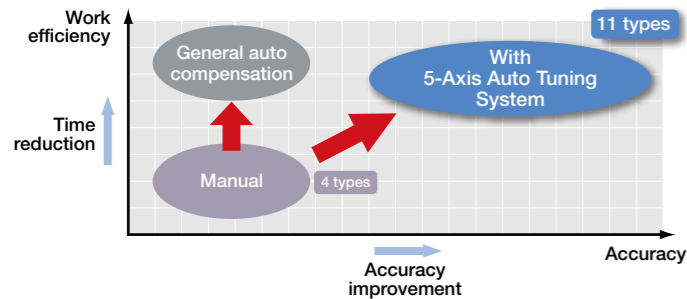
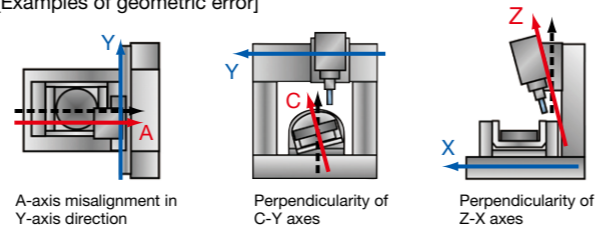

High accuracy 5-axis machining is maintained over long periods of time

Thermo-Friendly Concept The unique approach of "accepting temperature changes"

Accuracy changes due to changes in ambient temperature or spindle heat are minimized.

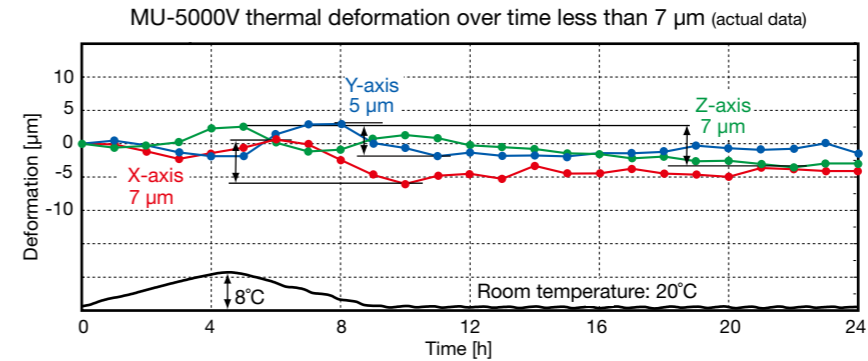

Note: The data mentioned in this brochure are "actual data" and do not represent guaranteed accuracies.

High accuracy maintained with 5-axis machining

Stable high-accuracy 5-axis machining is achieved even in a typical factory environment, with the synergistic effects of the Thermo-Friendly Concept and the 5-Axis Auto Tuning System.

Thermo-friendly structure gives outstanding dimensional stability

- 1. Minimal temperature deviation
- 2. Manageable thermal deformation
- 3. Accurate compensation

Thermo Active Stabilizer—Construction (TAS-C)
Thermo Active Stabilizer—Spindle (TAS-S)

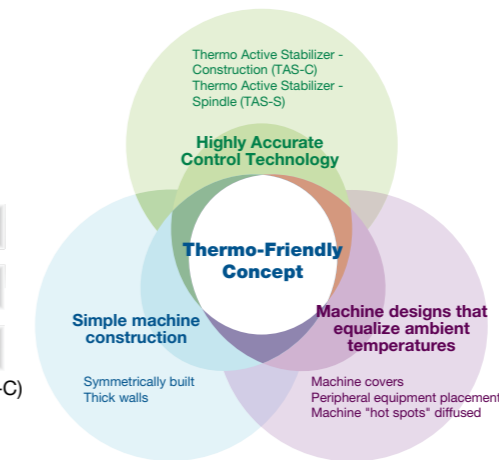

Machining dimensional change over time minimized with outstanding dimensional stability

Eliminate waste with the Thermo-Friendly Concept

Okuma's Thermo-Friendly Concept achieves high dimensional stability not only when the room temperature changes, but also at machine startups or when machining is resumed.

The warm-up operation time to stabilize thermal deformation is shortened, and the burden of dimensional correction when resuming machining is reduced.

- Machine startup
- Machining restart
- Room temp change

High dimensional stability

TAS-C (Thermo Active Stabilizer—Construction)

TAS-C estimates and accurately controls the volumetric thermal deformation of the machine's construction due to ambient temperature changes; based on data from properly placed sensors, feed axis positions, and actual machine thermal deformation characteristics.

TAS-S (Thermo Active Stabilizer—Spindle)

The TAS-S spindle thermal deformation control takes into account various conditional changes such as the spindle's temperature data, modification of the spindle rotation and speed, as well as spindle stoppage. The spindle's thermal deformation will be accurately controlled, even when the rotating speed changes frequently.

Get a real sense of the good visibility and operability demanded in 5-axis machining

Superb operator access to the machining chamber

- Structure allows easy tool edge confirmation during setup and machining
 - Best table, spindle, and operation panel layout in terms of operability
- Large step platform for easy working
 - Operating stress reduced with large platform so that operator does not have to worry about footing
- Large window for good visibility in machining chamber



Operator platform

Reduction of the chip discharge operation with smooth washing

- Workpieces and machining chamber are washed through in-machine workpiece washing and with washers on the saddle, to reduce manual washing work and increase efficiency

Chip cleaning by swinging the table, which is possible only with 5-axis control

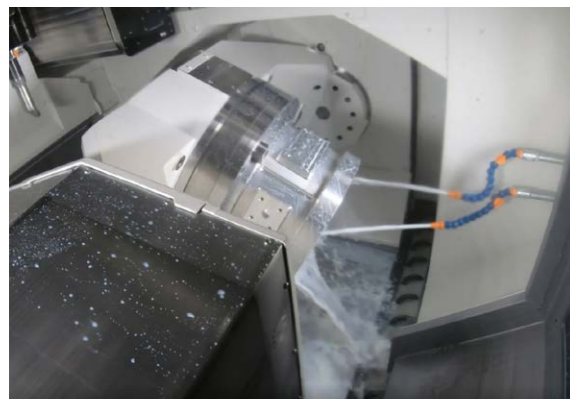

In-machine workpiece wash nozzle (option)

Quick and smooth chip discharge with saddle-mounted washer and in-machine coil chip conveyor



Washer on saddle (standard)

Process-intensive machining with turning capacity that approaches that of a lathe

Process-intensive machining and high-accuracy 1-chuck machining achieved with multitasking in which turning can also be done

Turning spindle

MU-5000V-L

- Table spindle speed: 1,000 min⁻¹
- Max output: 17/13 kW (15 min/cont)
- Max torque: 621/477 N-m (15 min/cont)

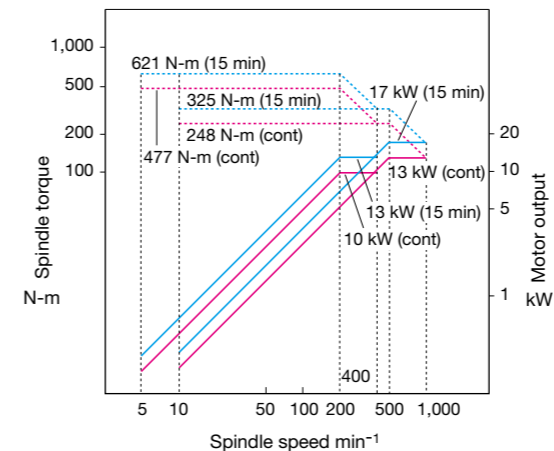

MU-6300V-L, MU-8000V-L

- Table spindle speed: 800 min⁻¹
- Max output: 16/12 kW (15 min/cont)
- Max torque: 1,019/764 N-m (15 min/cont)

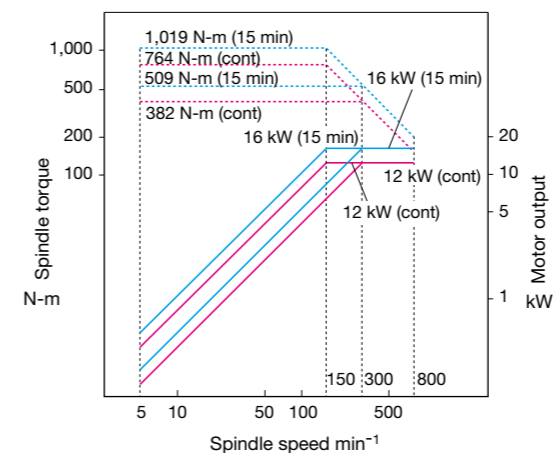

Turning capacity: 3 mm² (S45C)

- Machining dia: $\phi 164$ mm [$\phi 250$ mm]
- Cutting speed: 130 m/min (table rotation: 252 min⁻¹)
- Feed rate: 0.6 mm/rev
- Cutting depth: 5 mm []: MU-6300V, MU-8000V specs

Note: The "actual data" referred to above for this brochure represent examples, and may not be obtained due to differences in specifications, tooling, cutting condition, and others.

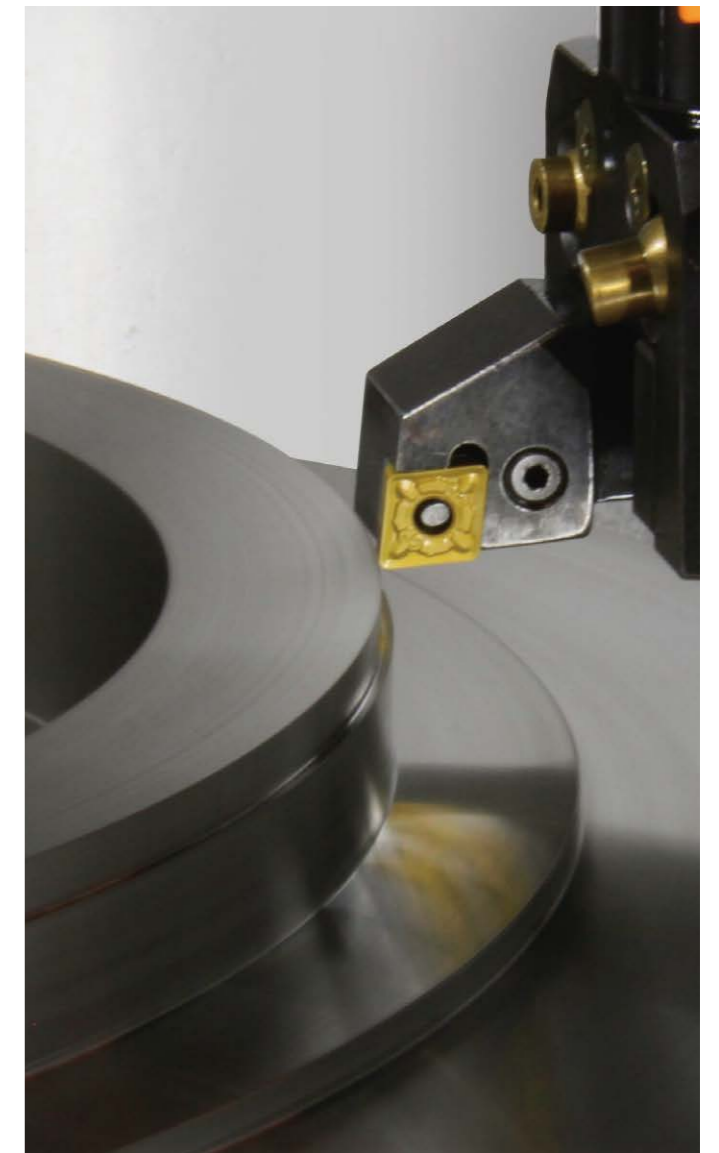

Productivity can be further improved with a wide array of manpower-saving and automation options

Flexible automation options

ATC magazines

- 48 tools, 64 tools: Chain magazine system
- Over 64 tools: Matrix magazine system
Short frame: 64, 98, 132, 166 tools
Long frame: 200, 234, 268 tools



Matrix magazine
(Photographed without front covers)

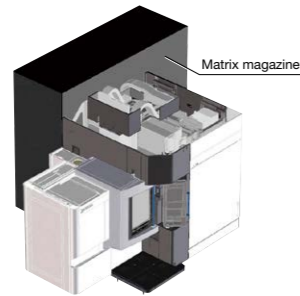

Matrix magazine specifications
for No. 50 short frame

Auto pallet changer (APC)

- External setup of workpiece preparations improve machine utilization
- Good access to machine interior even with APC specs
- Turning specs can also be selected



APC setup station



MU-6300V 2-pallet APC specs

Extra ports for complex hydraulic/pneumatic fixture arrangements

- Max ports: 8 ports* (option)

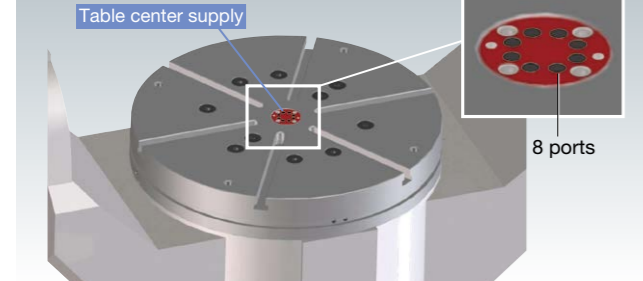

Note: The number of ports for turning or APC applications differ.

Auto tool gauging with workpiece mounted

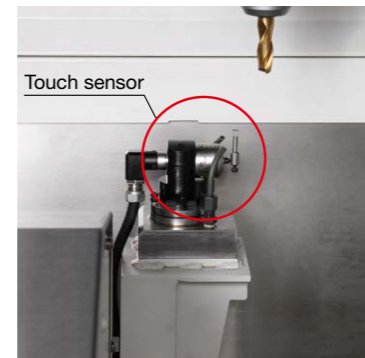

Tool breakage detection/
Auto tool length compensation

Automatically measures workpiece alignment and dimensions



Auto zero offset / Auto gauging
(radio transmission)

Safe, reliable chip discharge

Excellent chip discharge



In-machine chip discharge (coil)



Off-machine chip discharge (lift-up chip conveyor) (option)

Recommended chip conveyors (Please contact an Okuma sales representative for details.)

○: Recommended
△: Recommended with conditions

Workpiece material		Steel	FC	Aluminum / Nonferrous	Mixed (general use)
Chip shape					
In-machine	Coil (Standard)	○	○ (Dry-Wet)	—	○
	Hinge (floor)	○	—	—	△*1
Off-machine (option)	Scraper	—	○ (Dry)	—	—
	Scraper (with drum filter)	—	○ (Wet) with magnet	△*2	—
	Hinge + scraper (with drum filter)	△*3	△ (Wet)*4	○	○

*1. When there are few fine chips *2. When chips are shorter than 100 mm *3. When there are many fine chips *4. When chips are longer than 100 mm

Off-machine lift-up chip conveyors

Type	Hinge (floor)	Scraper	Scraper (with drum filter)	Hinge + scraper (with drum filter)
Shape				

Note: Chip conveyor with drum filter when Sludgeless Tank (option) is selected.

Contribution to the realization of a carbon-free society

Highly productive, accurate and eco-friendly **Green-Smart Machine**

Okuma has worked to reduce energy consumption in order to achieve carbon neutrality at the three factories in Japan which are our main production bases.

We have realized high productivity through automation and process-intensive machining, in addition to high-accuracy machining, and we then introduced the use of green energy to transform the three domestic factories into carbon-neutral factories.

“Green-Smart Machines” is our definition of Okuma’s intelligent machine tools, which autonomously achieve stable dimensional accuracy and reduced energy consumption, to support environmentally friendly production. Our policy is to deploy “Green-Smart Machines” fully, to help achieve a carbon-free society.

Starting with products manufactured at those carbon-neutral factories and supplying them all over the world, we will work together with our customers to help solve the social issues faced by the manufacturing industry.

Green-Smart Machines are **environmentally friendly** products that autonomously achieve stable dimensional accuracies and reduced energy consumption.

Green-Smart Machine Technology that achieves Green-Smart Machine

Thermo-Friendly Concept

The Okuma Intelligent Technology that enables machines to autonomously maintain high accuracy stability

The unique concept of accepting temperature changes achieves consistent high accuracy without special coolers or excessive air conditioning.

Reduction of warm-ups and dimensional compensation

Reduce the time needed for daily warm-ups and dimensional compensation to adjust to ambient temperature changes

Reduction of power used for air conditioning

Maintain high stability of dimensional accuracy even if the air conditioning temperature range is expanded.

Reduction of machine body coolers

Achieve outstanding dimensional accuracy without any special machine body cooling being required to maintain accuracy

The Okuma way to cool

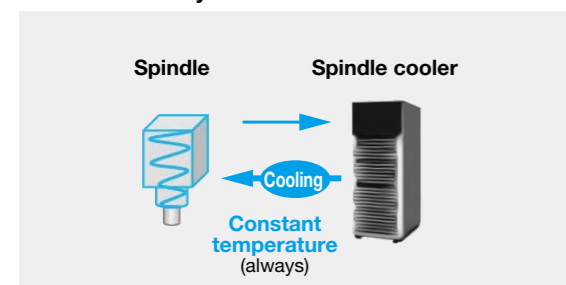

By always setting a constant coolant supply temperature, the cooler power consumption is reduced.

ECO suite plus

A system for an energy-saving society

ECO Idling Stop

Auxiliary equipment consume a substantial portion of the power used in a factory. This function enables each of them to be turned off when not needed to reduce power consumption. In addition to when automatic operation is suspended, it is now possible to stop idling during manual operation. Power consumption and carbon dioxide emissions are reduced without conscious effort by the operator.

The machine monitors the cooling level when not machining, and proactively turns off the cooler while maintaining high accuracy conditions.

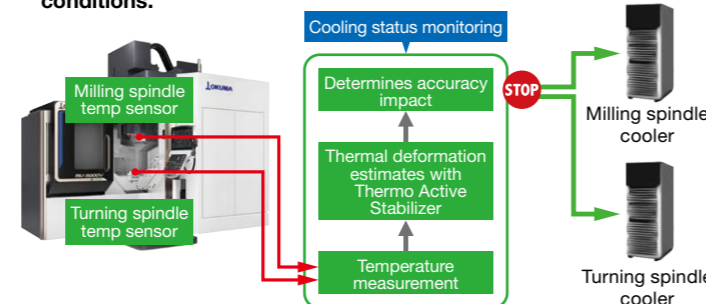

ECO Power Monitor

Power is shown individually for spindle, feed axes, and auxiliaries on the OSP operation screen. In addition to regenerative power, the energy-saving benefits from auxiliary equipment stopped with ECO Idling Stop can be confirmed on the spot.

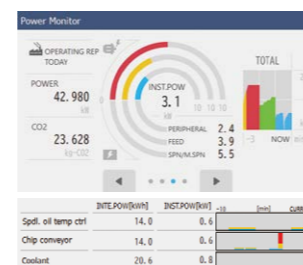

ECO Operation

By using only the required peripherals (chip conveyor, mist collector), energy-saving operations are possible.

Sludgeless Tank (option)

Reducing waste oil by suppressing coolant deterioration

Troublesome coolant tank cleaning work is reduced dramatically to increase productivity. In addition, the environmental impact caused by the disposal of coolant is reduced.

It is important to remove impurities (sludge) contained in the coolant for the stable operation of the machine, and coolant tank cleaning is indispensable. The Sludgeless Tank (option) circulates coolant at a constant speed in the tank to effectively collect sludge even during non-machining while reducing defects caused by the sludge contained in the coolant, such as scratches on machined surfaces and troubles of cutters, as well. Sludge accumulation in the tank is suppressed, which also drastically reduces the frequency of troublesome tank cleaning and enables stable operation over long hours. In addition, the frequency of coolant replacement can be greatly reduced, which also reduces the environmental impact of coolant disposal. In the thru-spindle coolant specification (option), the bag filter collects even finer sludge to improve the quality of machined surfaces.

Note: It is necessary to select the drum filter type chip conveyor if the Sludgeless Tank option is chosen.

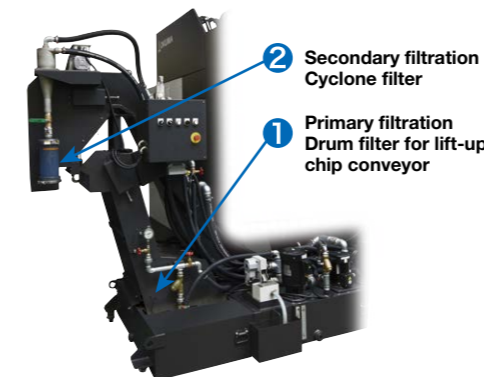

Tank structures vary by model or specification.

Sludge removal rate

99% (when the material is casting and aluminum)

Note: After secondary filtration (cyclone filter) permeation Okuma evaluated removal rate

No tank cleaning for 3 years (okuma equipment actual data)

No coolant replacement for 3 years (okuma equipment actual data)

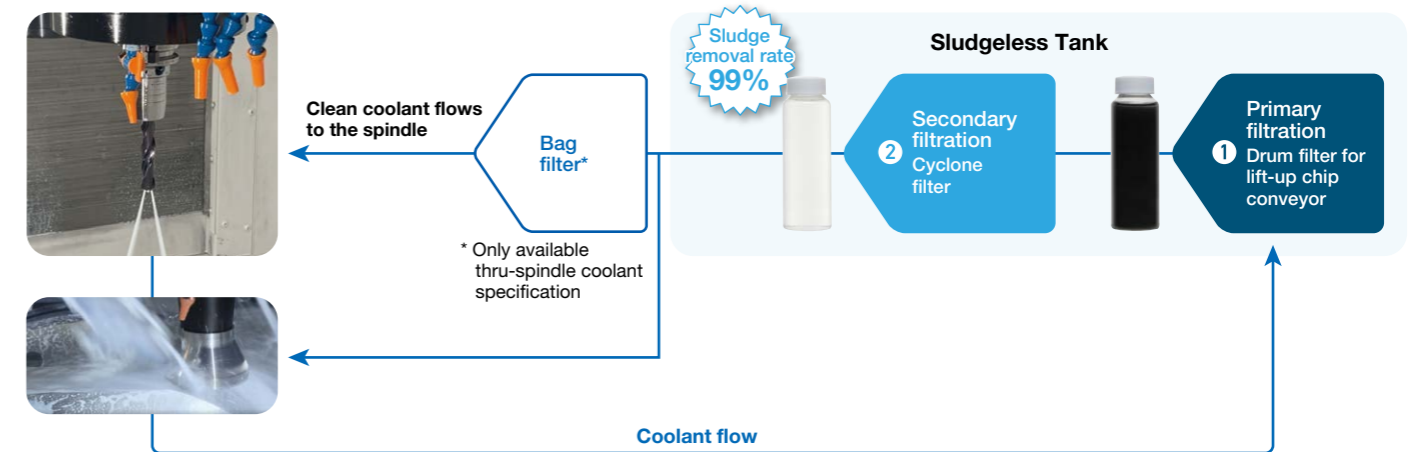

Advanced technology in OSP enhances machine shop performance

Machining Navi M-i, M-g II+ (option) Cutting condition search for milling

Maximizing machine tool performance

Automatically changes to optimum spindle speed (M-i)

Sensors built in to the machine detect and analyze machining chatter. Machining Navi then navigates to the effective measures in a wide range of spindle speeds, from low to high.

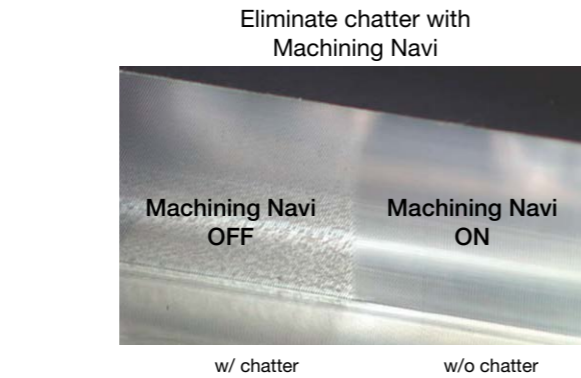
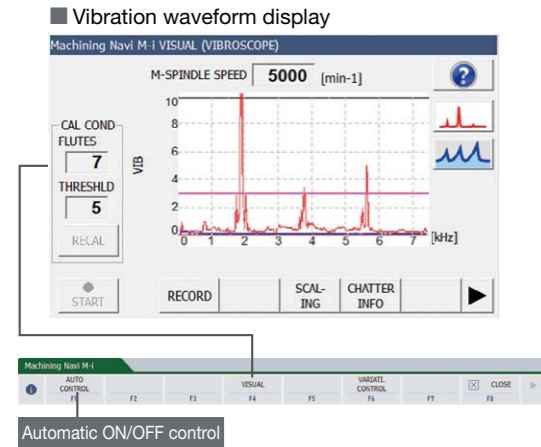

Adjust cutting conditions while monitoring the data (M-g II+)

Based on the chatter noise captured by the microphone, Machining Navi displays a number of optimal spindle speed possibilities on the screen. The operator can change to the indicated spindle speed with a single touch and immediately confirm the result.

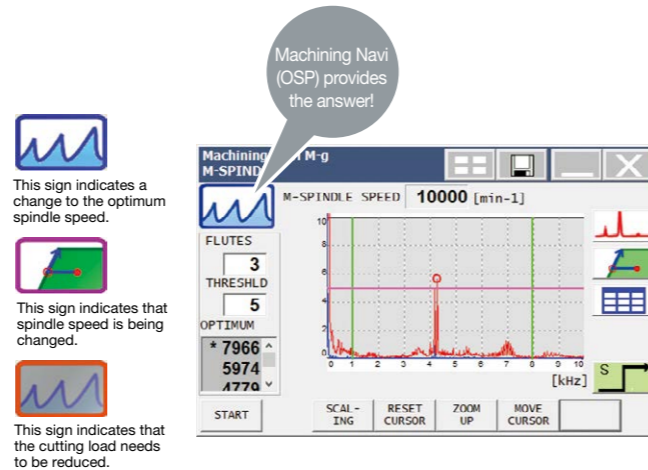

Collision Avoidance System (option) Collision prevention

World's first "Collision-Free Machine"

CAS prevents collisions in automatic or manual mode, providing risk-free protection for the machine and great confidence for the operator.

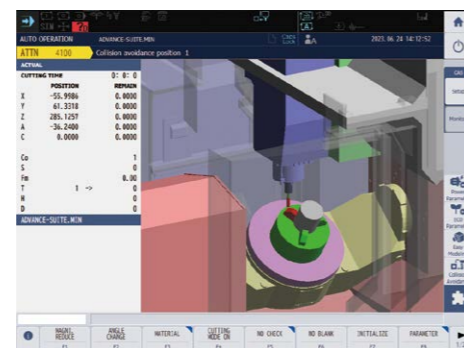

SERVONAVI Optimized Servo Control

Achieves long term accuracy and surface quality

SERVONAVI AI (Automatic Identification)

Work Weight Auto Setting Cycle time shortened with faster acceleration

On table travel type machining centers, the table feed acceleration with the previous system was the same regardless of weight, such as workpieces and fixtures loaded on the table.

Work Weight Auto Setting estimates the weight of the workpiece and fixture on the table and automatically sets the linear axis servo parameters, including acceleration, to the optimum values. Cycle times are shortened with no changes to machining accuracy.

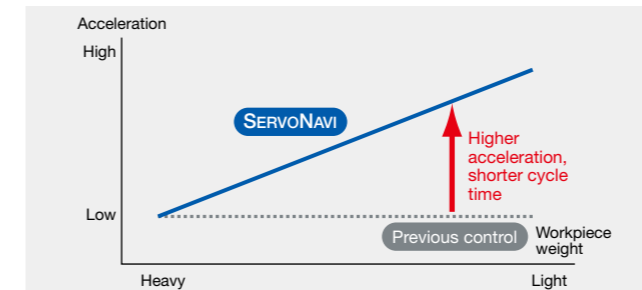

Rotary Axis Inertia Auto Setting Maintains high accuracy and stable movements

Depending on the workpiece or fixtures, inertia will vary, and with each variation the rotary axis positioning error in some cases became much larger.

Rotary Axis Inertia Auto Setting is able to estimate inertia from workpiece/fixture acceleration and deceleration, and automatically set the optimum the rotary axis servo parameters to maintain highly accurate and stable machine movements.

SERVONAVI SF (Surface Fine-tuning)

Reversal Spike Auto Adjustment Maintains machining accuracy and surface quality

Slide resistance changes with length of time machine tools are utilized, and discrepancies occur with the servo parameters that were the best when the machine was first installed. This may produce crease marks at motion reversals and affect machining accuracy (part surface quality). SERVONAVI's Reversal Spike Auto Adjustment maintains machining accuracy by switching servo parameters to the optimum values matched to changes in slide resistance.

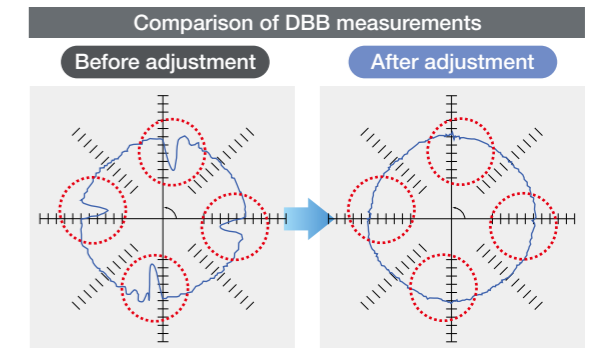

Vibration Auto Adjustment Contributes to longer machine life

When aging changes machine performance, noise, vibration, crease marks, or fish scales may appear. Vibration Auto Adjustment can quickly eliminate noise and vibration even from machines with years of operation.

AI Machine Diagnosis (option) Machine tool diagnostics technology with artificial intelligence (AI)

With predictive maintenance, prevent machine stoppages just in time

Okuma's AI-equipped control diagnoses the presence or absence of abnormalities in the machine spindle and feed axes and identifies any irregularities found.

Downtime from machine stoppage is minimized, so the benefits are highly accurate, productive, and stable operations over the long term. The operators themselves can easily diagnose the machine by following simple screen guidelines on the Okuma control.

Notes:

AI diagnostic models are already installed, and diagnoses can be performed by the machine itself. AI diagnostic models can be updated through Okuma's Connect Plan.

Feed axis diagnosis is for linear axes.

With AbsoScale detection specs, ball screw wear detection is possible.

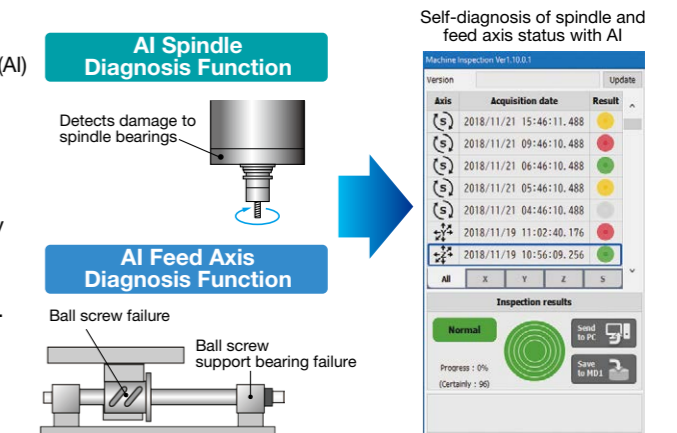

Advanced technology in OSP enhances machine shop performance

Hyper-SurfaceII (option)

Easy and improved die/mold surface quality

By suppressing streaks and edge irregularities caused by CAM machining data, hand finish polishing time can also be reduced. In addition to the Sculptured-Surface Adaptive Acceleration Control with the previous Super-NURBS, the new Hyper-Surface function automatically compensates for edge positioning errors of the machining data output from CAM or the adjacent cutting path while maintaining shape accuracy.

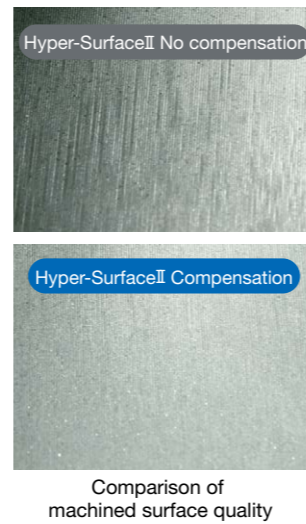
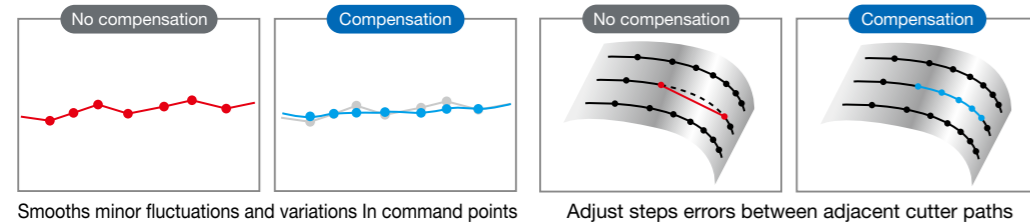

Dynamic Tool Load Control (option)

Prevents chipping, extends tool life

When machining of difficult-to-cut material, chipping from blade runout often occurs with insert-type end mills. To stabilize such machining, solid end mills with high tool costs have generally been used. Dynamic Tool Load Control gives uniform cutting force with

advanced synchronization of spindle phase and feed rate to control insert-type end mill chipping. This improves tool life and stabilizes machining. Switching from expensive solid tools also leads to reduced tool costs.

[Actual results] Chip volume per tool under the same cutting conditions (tool life)

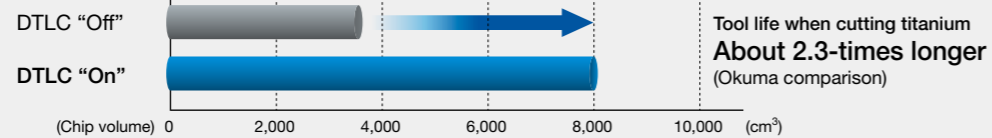

Runout of insert-type end mill tool edge

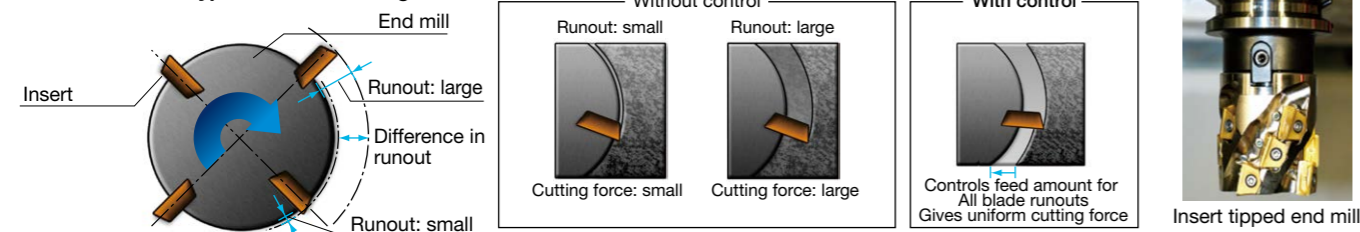

Note: The above are actual examples. Your results may vary due to differences in specifications, tooling and cutting conditions.

With simultaneous 5-axis control that produces excellent machined surface quality

Even easier to use with simultaneous 5-axis kits

Tool center point manual feed (option)

This feature will provide rotary operation with a tool point as the center when operating the rotary axes manually. When the table is swiveled, axis movement will occur with no change in the tool position on the workpiece.

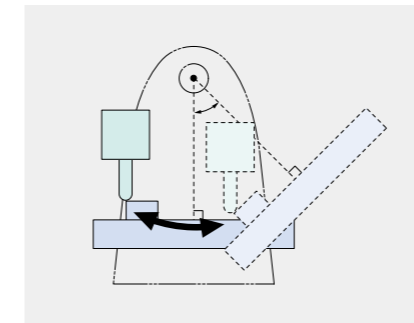
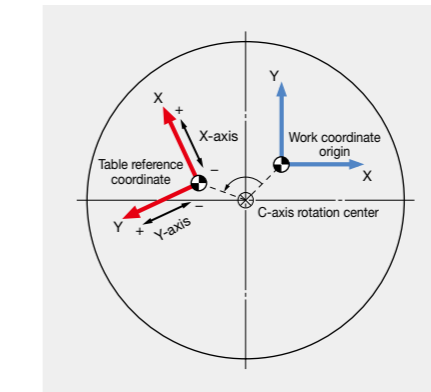

Table origin coordinate manual feed (option)

A feature to perform X-Y-Z-axis manual feed (rapid traverse, cutting feed, pulse handle) when origin coordinate systems shift on a swiveling table.



Tool center point control II (option)

Function controls the path of the tool tip with respect to the workpiece on each axis so that the tool tip trajectory is linear with the axis travel command including the A, B, and C axes.

- In the case of simultaneous Y-axis and A-axis commands with the linear command (G01), the tool path is a straight line when viewed from the workpiece.

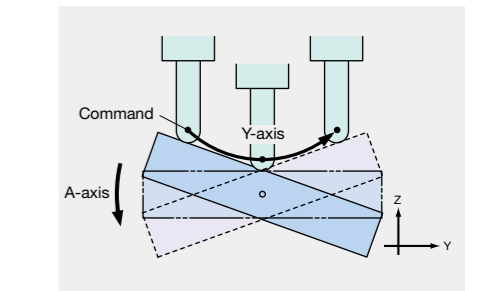

Tool Tilt Compensation (Included in Tool Center Point Control II)

The tool angle on a workpiece (tool tilt) in 5-axis machining will change on a waving surface. CAM processing errors will cause the tool to stagger with unnecessary accel /decel and reverse angles during axis feed. Simul 5-Axis TTC will keep feed rates steady with a smooth sequence of commands to automatically correct tool tilt angles—resulting in shorter cycle times and smoother surface finishes.

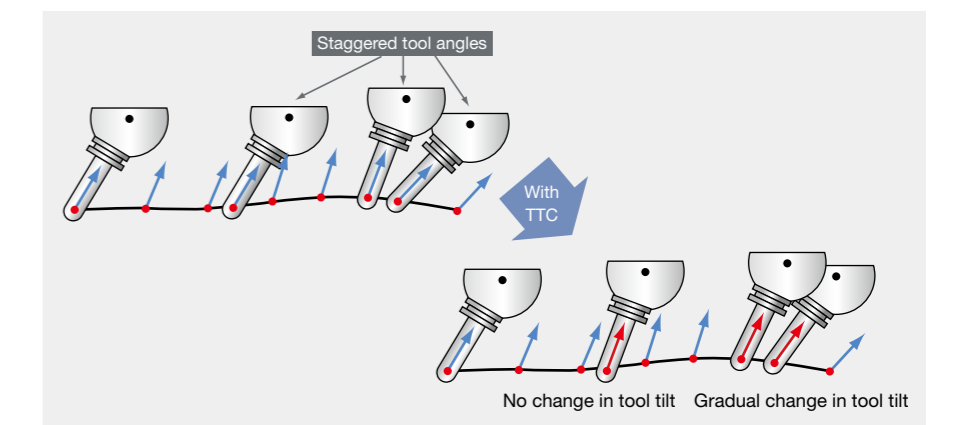

Machine specifications

	Item	Unit	MU-5000V (-L) No. 40 spindle	MU-5000V (-L) No. 50 spindle	MU-6300V (-L) No. 40 spindle	MU-6300V (-L) No. 50 spindle	MU-8000V (-L) No. 40 spindle	MU-8000V (-L) No. 50 spindle
Travels	X-axis (table L/R)	mm (in)	800 (31.50)		925 (36.42)		925 (36.42)	
	Y-axis (spindle saddle front / back)	mm (in)	1,050 (41.34)		1,050 (41.34) (+100 ATC movements)		1,050 (41.34) (+100 ATC movements)	
	Z-axis (spindlehead up / down)	mm (in)	600 (23.62)		600 (23.62)		600 (23.62)	
	A-axis (trunnion table rotation)	deg	+90 to -120		+90 to -120		+90 to -120	
	C-axis (table rotation)	deg	360 (infinite)		360 (infinite)		360 (infinite)	
	Table surface to spindle nose	mm (in)	80 to 680 (3.15 to 26.77)		160 to 760 (6.30 to 29.92)		200 to 800 (7.87 to 31.50)	
Table	Table size	mm (in)	ø500 (19.69)		ø630 (24.80)		ø800 (31.50) × 630 (24.80) width <ø800 (31.50)>	
	Max work size*1	mm (in)	ø700 × H500 (ø27.56 × H19.69)		ø830 × H550 (ø32.68 × H21.65)		ø1,000 × H550 (ø39.37 × H21.65)	
	Floor to table top	mm (in)	1,140 (44.88)		1,150 (45.28)		1,210 (47.64)	
	Max load capacity*1	kg (lb)	500 (1,100)		600 (1,320)		700 (1,540)	
	<Turning spindle speed>	min ⁻¹	<1,000>		<800>		<800>	
Spindle	Speed	min ⁻¹	10,000 [15,000, 20,000, 25,000] <8,000, [12,000, 20,000]>	6,000 [12,000] <10,000>	10,000 [15,000, 20,000, 25,000] <8,000, [12,000, 20,000]>	6,000 [12,000] <10,000>	10,000 [15,000, 20,000, 25,000] <8,000, [12,000, 20,000]>	6,000 [12,000] <10,000>
	Tapered bore		7/24 taper No. 40 <HSK-A63>	7/24 taper No. 50 <HSK-A100>	7/24 taper No. 40 <HSK-A63>	7/24 taper No. 50 <HSK-A100>	7/24 taper No. 40 <HSK-A63>	7/24 taper No. 50 <HSK-A100>
	No. of spindle ranges		Infinitely variable		Infinitely variable		Infinitely variable	
	Bearing dia	mm (in)	ø70 (2.76)	ø90 (3.54)	ø70 (2.76)	ø90 (3.54)	ø70 (2.76)	ø90 (3.54)
Feed	Rapid traverse	m/min (ipm)	X-Y-Z: 50 (1,969)		X-Y-Z: 50 (1,969)		X-Y-Z: 50 (1,969)	
	Rapid traverse	deg/min	A: 18,000 (50 min ⁻¹) C: 18,000 (50 min ⁻¹) <36,000 (100 min ⁻¹)>		A: 10,800 (30 min ⁻¹) C: 32,400 (90 min ⁻¹)		A: 10,800 (30 min ⁻¹) C: 32,400 (90 min ⁻¹)	
	Cutting feed rate	mm/min	X-Y-Z: 1 to 50,000		X-Y-Z: 1 to 50,000		X-Y-Z: 1 to 50,000	
Motors	Spindle (10 min/cont)	kW (hp)	11/7.5 (15/10) [22/18.5 (30/25), 30/22 (40/30), 15/11 (20/15)] <11/7.5 (15/10), [22/18.5 (30/25), 30/22 (40/30)]>	11/7.5 (15/10) [26/18.5 (35/25)] <26/18.5 (35/25)>	11/7.5 (15/10) [22/18.5 (30/25), 30/22 (40/30), 15/11 (20/15)] <11/7.5 (15/10), [22/18.5 (30/25), 30/22 (40/30)]>	11/7.5 (15/10) [26/18.5 (35/25)] <26/18.5 (35/25)>	11/7.5 (15/10) [22/18.5 (30/25), 30/22 (40/30), 15/11 (20/15)] <11/7.5 (15/10), [22/18.5 (30/25), 30/22 (40/30)]>	11/7.5 (15/10) [26/18.5 (35/25)] <26/18.5 (35/25)>
	Feed axes	kW (hp)	X: 5.2 (6.9), Y-Z: 3.5 (4.7), A: 3.5 × 2 (4.7 × 2)		X: 5.2 (6.9), Y-Z: 3.5 (4.7), A: 4.6 × 2 (6.1 × 2)		X: 5.2 (6.9), Y-Z: 3.5 (4.7), A: 4.6 × 2 (6.1 × 2)	
	Feed axes (C-axis: milling)	kW (hp)	C: 3.0 (4) <5.0 (6.7)>		C: 7.2 (9.6)		C: 7.2 (9.6)	
	Turning (15 min/cont)	kW (hp)	<17/13 (23/17)>		<16/12 (21/16)>		<16/12 (21/16)>	
Auto tool changer (ATC)	Tool shank		MAS BT40 <HSK-A63>	MAS BT50 <HSK-A100>	MAS BT40 <HSK-A63>	MAS BT50 <HSK-A100>	MAS BT40 <HSK-A63>	MAS BT50 <HSK-A100>
	Pull stud		MAS2 <->		MAS2 <->		MAS2 <->	
	Tool capacity (magazine)		32-tool [48-tool, 64-tool: chain, Over 64-tool: matrix*2]		32-tool [48-tool, 64-tool: chain, Over 64-tool: matrix*2]		32-tool [48-tool, 64-tool: chain, Over 64-tool: matrix*2]	
	Max tool dia (w/adjacent / w/o adjacent)	mm (in)	ø90/ø125 (ø3.54/ø4.92)	ø100/ø152 (ø3.94/5.98)	ø90/ø125 (ø3.54/ø4.92)	ø100/ø152 (ø3.94/5.98)	ø90/ø125 (ø3.54/ø4.92)	ø100/ø152 (ø3.94/5.98)
	Max tool length	mm (in)	400 (15.75)		400 (15.75)		400 (15.75)	
	Max tool mass	kg (lb)	8 (17.6)	12 (26.4) [15 (33)]	8 (17.6)	12 (26.4) [15 (33)]	8 (17.6)	12 (26.4) [15 (33)]
	Tool selection		Memory random (matrix magazine is fixed address system)		Memory random (matrix magazine is fixed address system)		Memory random (matrix magazine is fixed address system)	
Machine size	Height	mm (in)	3,435 (135.24)		3,525 (138.78)		3,625 (142.72)	
	Floor space W x D (w/o operator platform)	mm (in)	3,995 × 2,750 (157.28 × 108.27)	3,995 × 2,840 (157.28 × 111.81)	4,850 × 2,990 (190.94 × 117.72)	4,850 × 2,990 (190.94 × 117.72)	5,280 × 2,990 (207.87 × 117.72)	5,280 × 2,990 (207.87 × 117.72)
	Mass	kg (lb)	15,400 (33,880)	15,650 (34,430)	17,500 (38,500)	17,700 (38,940)	18,400 (40,480)	18,600 (40,920)
CNC		OSP-P500M-H <OSP-P500S-H>		OSP-P500M-H <OSP-P500S-H>		OSP-P500M-H <OSP-P500S-H>		

*1. With APC specifications, there are limits on maximum pallet load and maximum workpiece dimensions.

*2. Matrix magazines of 64, 98, 132 and 166 tools have short frames, while those of 200, 234 and 268 tools have long frames.

[]: Option

< >: Turning specifications

Standard specifications / accessories

No. 40 Spindle speed 50 to 10,000 min ⁻¹	11/7.5 kW (15/10 hp) [10 min/cont]
No. 50 Spindle speed 50 to 6,000 min ⁻¹	11/7.5 kW (15/10 hp) [10 min/cont]
Rapid feed rate	X-Y-Z: 50 m/min
Spindle-Spindlehead cooling system	Oil temperature controller
Ball screw cooling	X-Y-Z-axis
Air cleaner (filter)	Including regulator
Operation panel with color LCD	21.5-inch touch panel
Pulse handle	
Tapered bore cleaning bar	
A-/C-axis rotary table	0.0001 deg, Including encoder
C-axis table ^{*1}	MU-5000V ø500 mm, 6 18H7 T-slots
	MU-6300V ø630 mm, 6 18H7 T-slots
	MU-8000V ø800 × 630 mm width, 5 18H7 T-slots
Hand tools	
Tool release lever	
TAS-S	Thermo Active Stabilizer—Spindle
TAS-C	Thermo Active Stabilizer—Construction
Washing device on saddle	
Coolant supply system ^{*2}	MU-5000V Tank: 440 L [Effective: 289 L] Pump: 370 W (50 Hz), 550 W (60 Hz)
	MU-6300V Tank: 770 L [Effective: 350 L] Pump: 370 W (50 Hz), 550 W (60 Hz)
	MU-8000V Tank: 770 L [Effective: 350 L] Pump: 370 W (50 Hz), 550 W (60 Hz)
ATC air blower	
Chip air blower	Nozzle type
Operator platform	
Work lamp	LED (installed on right and left sides)
In-machine chip discharge	Coil type
Chip pan	MU-5000V: Effective capacity 77 L MU-6300V, MU-8000V: Effective capacity 92 L
Foundation washer (with jack bolts)	MU-5000V: 11 pcs MU-6300V, MU-8000V: 12 pcs
3-lamp status indicator	Type C (LED signal tower) Red (alarm), Yellow (end) Green (running)
ATC magazine	Tool capacity (magazine) 32-tool
ATC magazine shutter	
Full enclosure shielding	With ceiling (full enclosure)

*1. Turning specs have tapped holes (M16 x 24).

*2. Oil-based coolants are highly flammable, so fire prevention measures must always be taken when using these coolants. Do not operate unattended.
800 W pump required with oil-based coolant.

Optional specifications / accessories

Wide-range sp 50 to 15,000 min ⁻¹ △	No. 40 22/18.5 kW (30/25 hp) (10 min/cont) ^{*1}	
Wide-range sp 50 to 12,000 min ⁻¹ △	No. 50 26/18.5 kW (35/25 hp) (10 min/cont) ^{*2}	
High-speed sp 50 to 20,000 min ⁻¹ △	No. 40 30/22 kW (40/30 hp) (10 min/cont) ^{*1}	
High-speed sp 50 to 25,000 min ⁻¹ △	No. 40 15/11 kW (20/15 hp) (10 min/cont) ^{*1}	
Multitasking sp (turning specs)	50 to 8,000 min ⁻¹ △	11/7.5 kW (15/10 hp) (10 min/cont) ^{*3}
	50 to 12,000 min ⁻¹ △	22/18.5 kW (30/25 hp) (10 min/cont) ^{*3}
	50 to 20,000 min ⁻¹ △	30/22 kW (40/30 hp) (10 min/cont) ^{*3}
50 to 10,000 min ⁻¹ △	26/18.5 kW (35/25 hp) (10 min/cont) ^{*4}	
Dual contact spindle ^{*5} △	HSK, BIG-PLUS®	
AbsoScale	X-Y-Z axes	
Auto pallet changers ^{*6}	2-P, 6-P, 10-P, 12-P (parallel shuttle) 11-P (tower), FMS	
ATC tool capacities	△ 48-tool, 64-tool (chain type) 64-tool or more (matrix type)	
Pull stud specs	△ MAS1, JIS, CAT, DIN	
Table surface ^{*7} △	Tapped table top MU-8000V: ø800 round table	
Thru-spindle coolant ^{*8}	Specify 1.5 MPa or 7.0 MPa. 25,000 min ⁻¹ specs available for HSK-A63 only.	
Oil mist coolant		
Shower coolant	Ceiling mounted, 5 nozzles	
Workpiece wash gun		
Sludgeless Tank		
Off-machine chip discharge	△ Lift-up chip conveyors: floor type, drum filter type	
Chip bucket for above	△	
Hyper-Surface II		
Tool breakage detection/auto tool length compensation	Touch sensor (Renishaw) Laser sensor (Blum)	
Auto zero offset/auto gauging	Touch probe (Renishaw)	
5-Axis Auto Tuning System	Gauging, compensation for geometric error	
Collision Avoidance System	Collision prevention	
Machining Navi M-i, M-g II+	Cutting condition search function for milling/machining	
Tool life management (time counter, etc)		
Overload monitor (w/ feed adaptive control)		
Automatic door		
Chemical anchors		

△: Corresponding standard specification deleted.

*1. Spindle accepts 7/24 No. 40 (BT40, BIG-PLUS®, CAT40, DIN40), or HSK-A63 tapers.

*2. For spindle tapered bore, 7/24 taper No. 50 (BT50, BIG-PLUS®, CAT50, DIN50, HSK-A100 or CAPTO-C6) is available.

*3. Tapered bore on multitasking spindle is HSK-A63.

*4. Tapered bore on multitasking spindle is HSK-A100, CAPTO-C6.

*5. Be sure to select this specification when the BIG-PLUS® holder is used.

*6. Restrictions apply, such as compatible models, maximum workpiece dimensions, etc.

*7. With turning specifications, tapped holes only (no T-slots).

*8. Okuma pull stud required (End-face grinding, O-ring, and through-hole diameter differ from those of commercial pull studs.)

Wide-range spindle 50 to 15,000 min⁻¹ (option)

- Spindle taper No. 40
- Max output 22/18.5 kW (10 min/cont)
- Max torque 199/146 N-m (5 min/cont)

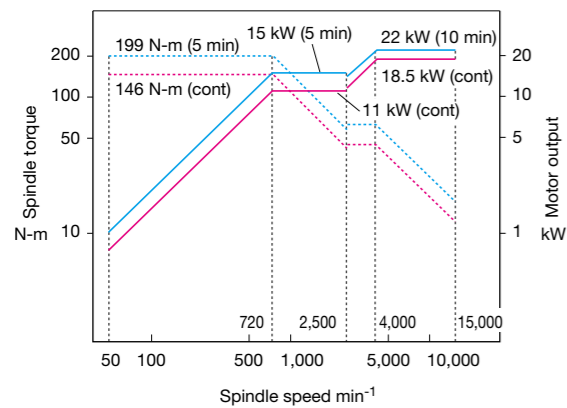

Wide-range spindle 50 to 12,000 min⁻¹ (option)

- Spindle taper No. 50
- Max output 26/18.5 kW (10 min/cont)
- Max torque 199/146 N-m (5 min/cont)

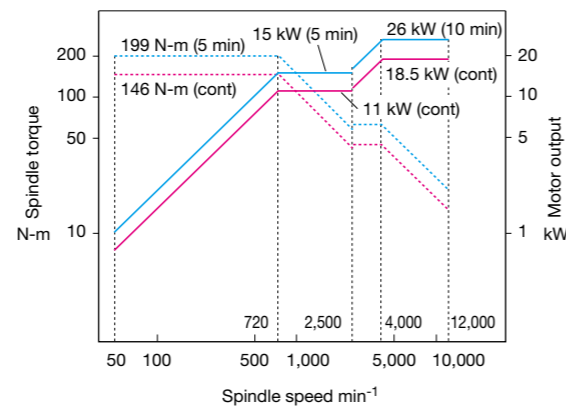

High-speed spindle 50 to 20,000 min⁻¹ (option)

- Spindle taper No. 40
- Max output 30/22 kW (10 min/cont)
- Max torque 57/42 N-m (10 min/cont)

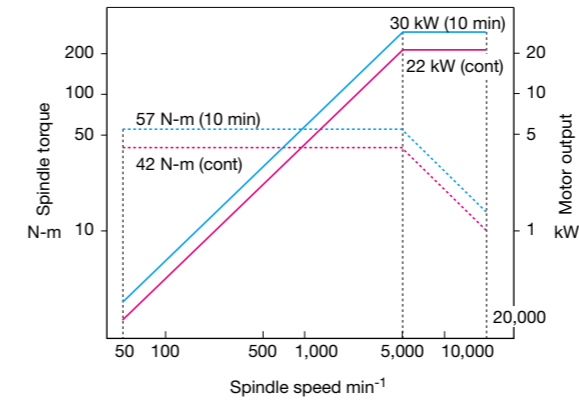

High-speed spindle 50 to 25,000 min⁻¹ (option)

- Spindle taper No. 40
- Max output 15/11 kW (10 min/cont)
- Max torque 29/20 N-m (10 min/cont)

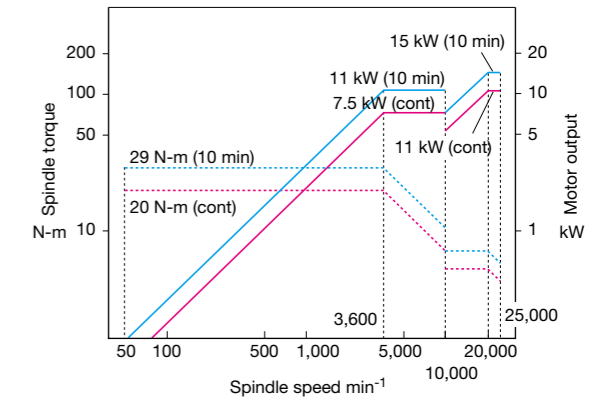

Multitasking spindle 50 to 8,000 min⁻¹ (option)

- Spindle taper HSK-A63
- Max output 11/7.5 kW (10 min/cont)
- Max torque 198/135 N-m (5 min/cont)

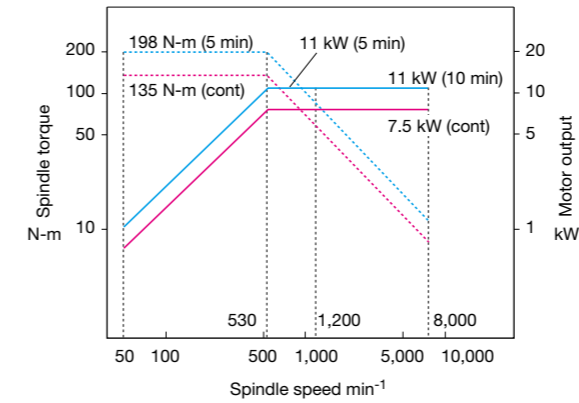

Multitasking spindle 50 to 12,000 min⁻¹ (option)

- Spindle taper HSK-A63
- Max output 22/18.5 kW (10 min/cont)
- Max torque 199/146 N-m (5 min/cont)

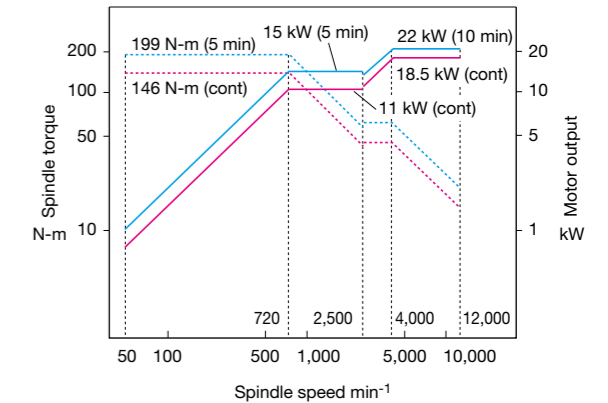

Multitasking spindle 50 to 20,000 min⁻¹ (option)

- Spindle taper HSK-A63
- Max output 30/22 kW (10 min/cont)
- Max torque 83/70/54 N-m (5 min/10 min/cont)

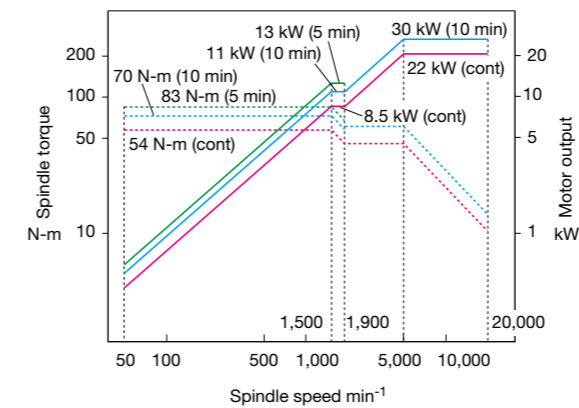

Multitasking spindle 50 to 10,000 min⁻¹ (option)

- Spindle taper HSK-A100
- Max output 26/18.5 kW (10 min/cont)
- Max torque 199/146 N-m (5 min/cont)

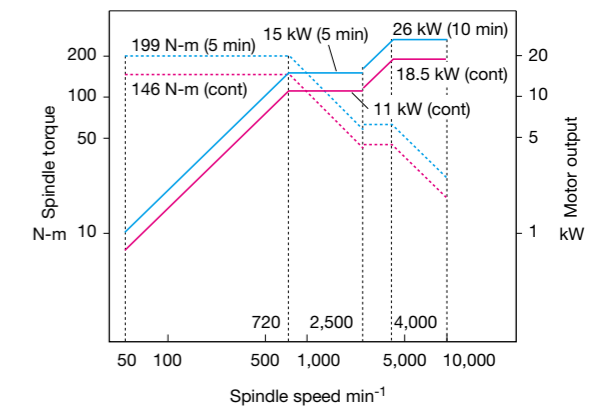

A next-generation CNC that makes manufacturing DX (digital transformation) a reality

OSP-P500

Improved productivity and stable production

As Your Single Source for M-E-I-K (Mechanics - Electronics - IT - Knowledge) maring technology, Okuma offers this CNC to build an advanced "digital twin" that faithfully reproduces machine control and machining operations and create new value. In addition, Okuma offers productivity improvement and stable production with ease of use that allows customers to use their machining know-how, an energy-saving solutions that achieve both high accuracy/productivity and eco-friendly products, with robust security protection against increasing threats of cyber attacks.



21.5-inch operation panel

Faithful reproduction of machines and processing — Digital support for shop floor work
Digital Twin (option)

"Okuma's **two** digital twins" made possible by an office PC and a next-generation CNC reduce machine downtime and improve machine utilization

Simulation using the latest machine information can be achieved with an office PC and OSP-P500 installed on the physical machine. This enables preparation for machining in advance in the office environment (front loading). Physical machine preparation time can be reduced by using digital twin preparation results to prepare for machining the next parts while machining continues. When a problem occurs on the shop floor, it can be solved quickly on site without going back to the office.

1 Digital Twin On PC^{*1}

Simulate shop machines in the office

Front loading is performed with the actual status matched with the data on the office PC to further improve productivity. Highly accurate pre-verification minimizes trial and error in first part machining, and reduces machine downtime to the minimum.

*1. The PC software is to be used with one package for one machine.

2 Digital Twin On Machine

Simulating the CNC of a real machine

Super-fast and super-accurate machining simulations are performed with the CNC of a real machine on-site to minimize machining preparation work. Actual machining can be started immediately, greatly improving the operating rate of the machine.



Connect Plan Get Connected, Get Started, and Get Innovative with Okuma "Monozukuri"

Connect, Visualize, Improve

Okuma's Connect Plan is a system that provides analytics for improved utilization by connecting machine tools and visual control of factory operation results and machining records. Simply connect the OSP and a PC and install Connect Plan on the PC to see the machine operation status from the shop floor, from an office, from anywhere. The Connect Plan is an ideal solution for customers trying to raise their machine utilization.

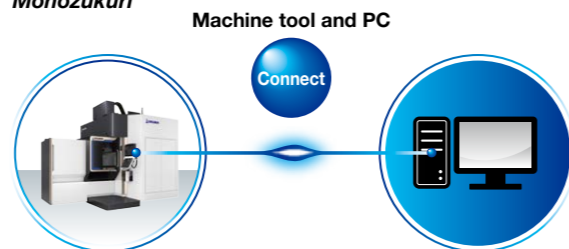

OSP-P500M/S standard specifications

Basic Specs	Control	X, Y, Z, A, C simultaneous 5-axis, spindle control (1 axis)
	Position feedback	OSP full range absolute position feedback (zero point return not required)
	Coordinate functions	Machine coordinate system (1 set), work coordinate system (20 sets)
	Min / Max command	±99999.999 mm, ±9999.9999° 8-digit decimal, command units: 0.001 mm, 0.01 mm, 1 mm, 0.0001°, 0.001°, 1°
	Feed	Cutting feed override: 0 to 200%
	Spindle control	Direct spindle speed commands, override 30 to 300%, multi-point indexing
	Tool compensation	No. of registered tools: Max 999 sets, tool length/radius compensation: 3 sets per tool
	Display	21.5-inch color LCD + multi-touch panel operations
	Security	Operator authentication, Lock screen, OSP-VPSII-STD
	Programming	Program capacity
	Program operations	Scheduled program, fixed cycle, G-/M-code macros, arithmetic, logic statements, math functions, variables, branch commands, Coordinate calculate, area machining, coordinate convert, programming help, user task, keyway cycle, fixture offset II
Operations	OSP suite	"suite apps" to graphically visualize and digitize information needed on the shop floor, "suite operation" enable one-touch access to "suite apps".
	Easy Operation	"Single-mode operation" to complete a series of operations. Advanced operation panel/graphics facilitate smooth machine control
	MacMan plus	Machining management: aggregation and display of machining records, operating records and problem information, Visualization of power consumption, file output
	Machine operations	Operation help, load meter, alarm help, sequence return, manual interrupt/auto return, pulse handle overlap, parameter I/O, PLC monitor, easy parameter setting
Communications / Networking		USB (2 ports), Ethernet, DNC-T1, Smart I/F
High speed/accuracy specs		Thermo Active Stabilizer—Spindle (TAS-S), Thermo Active Stabilizer—Construction (TAS-C), Hi-Cut Pro, Pitch error compensation, Hi-G control, SERVO NAVI, cycle time reduction
Energy-saving	ECO suite plus	ECO Idling Stop, ECO Operation, oil temperature controller auto control, ECO Power Monitor
	Power Regeneration System	Regenerative power is used when the spindle and feed axes decelerate to reduce energy waste.

OSP-P500M/S optional specifications

Item	Kit Specs	NML		AOT		DT		DT AOT	
		E	D	E	D	E	D	E	D
Digital Twin									
Virtual Machining						●	●	●	●
Quick Modeling						(VE)	(VD)	(VE)	(VD)
OPC UA for Machine Tools						●	●	●	●
OSP API KIT						●	●	●	●
Interactive functions									
Advanced One-Touch IGF-M (w/ Real 3-D simulation)				●	●			●	●
Interactive MAP (I-MAP)						●	●		
Smart OSP Operation				●	●	●	●	●	●
Programming									
Operation buffer 10MB		●	●	●	●	●	●	●	●
Program notes (MSG)		●	●	●	●	●	●	●	●
Auto scheduled program update		●	●	●	●	●	●	●	●
Block skip; 9 sets									
Program branch; 9 sets									
Coordinate system select (Std: 20 sets)	100 sets	●	●	●	●	●	●	●	●
	200 sets	●	●	●	●	●	●	●	●
	400 sets								
Helical cutting		●	●	●	●	●	●	●	●
3-D circular interpolation									
Synchronized Tapping II		●	●	●	●	●	●	●	●
Arbitrary angle chamfering		●	●	●	●	●	●	●	●
Cylindrical side facing									
Tool max rotational speed setting									
F1-digit feed	External switch type, parameter type								
Programmable travel limits (G22, G23)		●	●	●	●	●	●	●	●
Slope machining	Type I, Type II								
Dynamic fixture offset									
Gear Machining Package									
Hobbing and skiving									
Dynamic Tool Load Control									
3-D tool compensation									
Drawing conversion	Programmable mirror image (G62)			●	●	●	●	●	●
	Enlarge/reduce (G50, G51)			●	●	●	●	●	●
User task	Common variables 1,000, 2,000 pcs								
	G-code macros: 80 sets added								
	I/O variables (16 each)								
Sequence stop		●	●	●	●	●	●	●	●
Sequence return	Mid-block sequence return	●	●	●	●	●	●	●	●
Tool wear compensation	Includes input restriction	●	●	●	●	●	●	●	●
Tool life management	Includes warning	●	●	●	●	●	●	●	●
External I/O communication									
RS-232C connector									
DNC connection	DNC-T3, DNC-B, DNC-DT								
	DNC-C/Ethernet								
Gauging									
Auto tool length offset/breakage detection									
In-magazine tool breakage detection									
Auto Workpiece Gauging/Auto zero offset									
Manual gauging (w/o sensor)		●	●	●	●	●	●	●	●
Interactive gauging (touch sensor, touch probe required)									
NC Gage									
Monitoring									
One-Touch Spreadsheet									
Collision Avoidance System									
Real 3-D Simulation						●	●	●	●
Simple load monitor	Spindle overload monitor	●	●	●	●	●	●	●	●
NC operation monitor	Hour meter, workpiece counter	●	●	●	●	●	●	●	●
Status indicator									
Tool breakage no-load detection				●	●	●	●	●	●
MOP-TOOL	Adaptive control, overload monitor								
AI machine diagnostics *	Spindle/feed axes, or feed axes only								
Machine Status Logger									
Cutting Status Monitor									
Machining Navi M-i, M-g II+(cutting condition search)									
Feed axis retraction									
Tool retract cycle									
Automation / unattended operation									
Auto power shut-off	M02 and END alarms, work preps done → OFF	●	●	●	●	●	●	●	●
Warm-up (calendar timer)									
External program	Button, rotary switch								
	Digital switch, BCD (2-digit, 4-digit)								
Connection with automated devices	Robot, loader I/F								
	Stacker crane I/F								
	FMS link I/F								
High-speed, high-precision									
AbsoScale detection	X-Y-Z axes								
5-Axis Auto Tuning System									
Dynamic displacement compensation		●	●	●	●	●	●	●	●
0.1 μm control (linear axis commands)									
Hyper-Surface II	3 linear axes, 3 linear axes + 2 rotary axes								
5-axis machining									
Tool center point control II (w/ tool tilt comp)									
Tool tilt command									
Cutting point command									
Tool side machining									
Leading edge offset									
Tool side offset									
Tool-axial tool length comp									
Manual feed	Manual tool feed (tool-axial), manual tool feed (right angle)								
	Table origin coordinate system manual feed								
	Tool center point manual feed								
ECO suite plus									
ECO Power Monitor	On-machine wattmeter								
Spindle Power Peak Limiter									
External output interface of consumed electricity									
Other									
Simultaneous 5-axis kit									
5-Axis Auto Tuning System kit									
NC Gage kit									
Circuit breaker									
OSP-VPSII (Virus Protection System)									
External M codes [4 sets, 8 sets]									

Note. NML: Normal kit, AOT: Advanced One-Touch IGF-M kit, DT: Digital Twin kit, DT AOT: Digital Twin Advanced One-Touch IGF-M, E: Economy, D: Deluxe
VE and VD kits are also equipped with the Digital Twin on PC function, allowing running from a PC.

Working range (w/o APC)

Unit: mm

MU-5000V

Max table load capacity: 500 kg

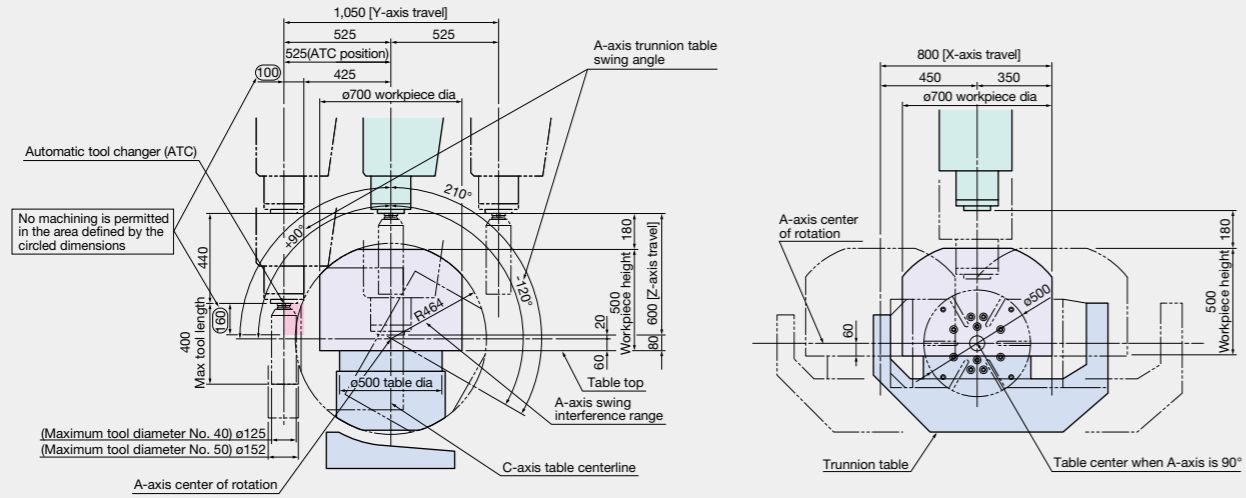

Working range (with APC)

Unit: mm

MU-5000V (P)

Max pallet load capacity: 400 kg

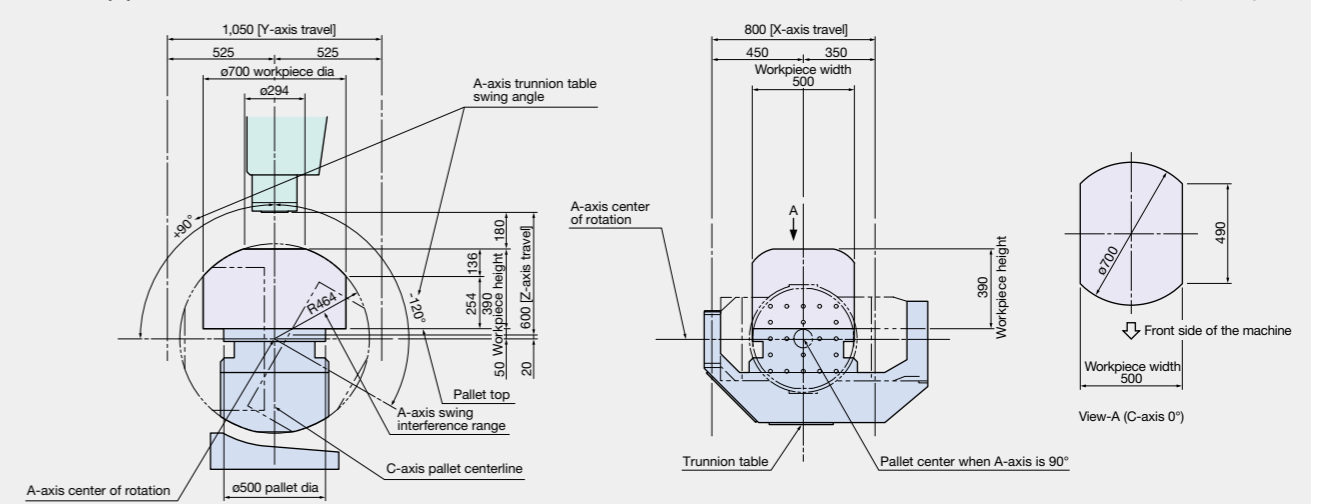

MU-6300V

Max table load capacity: 600 kg

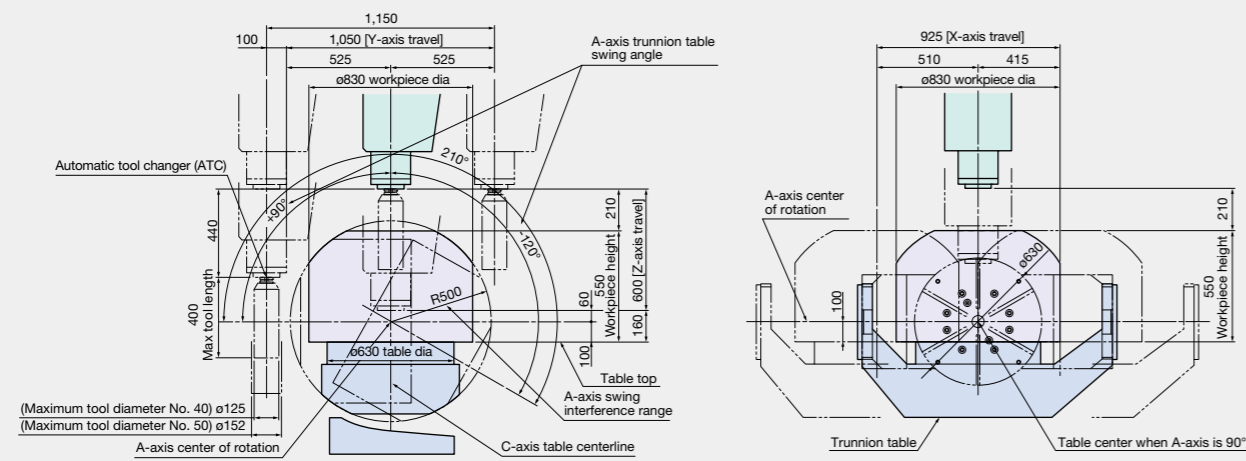

MU-6300V (P)

Max pallet load capacity: 450 kg

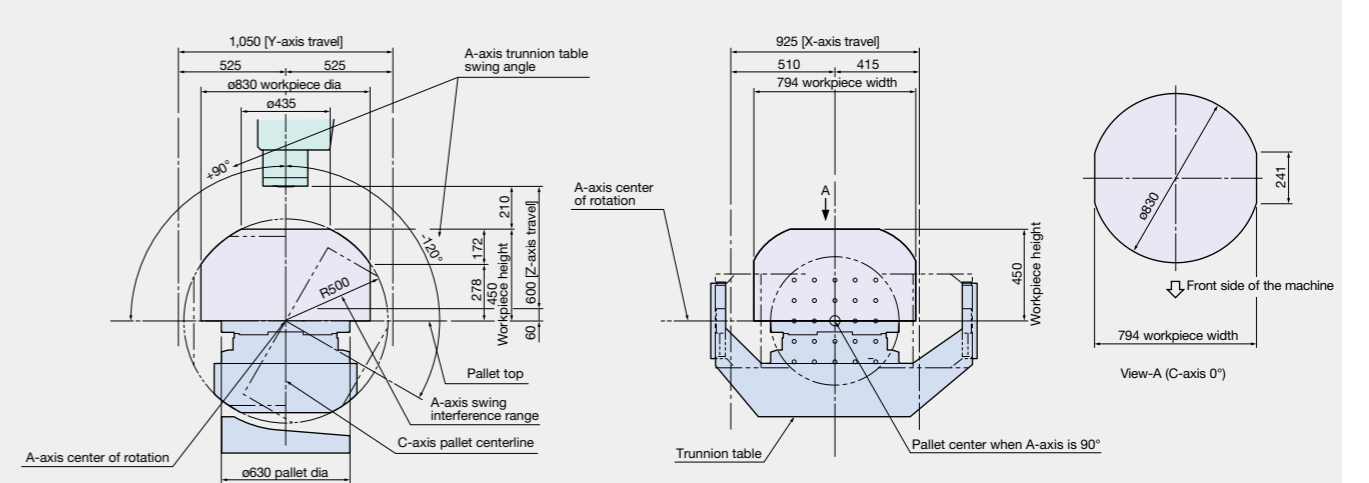

MU-8000V

Max table load capacity: 700 kg

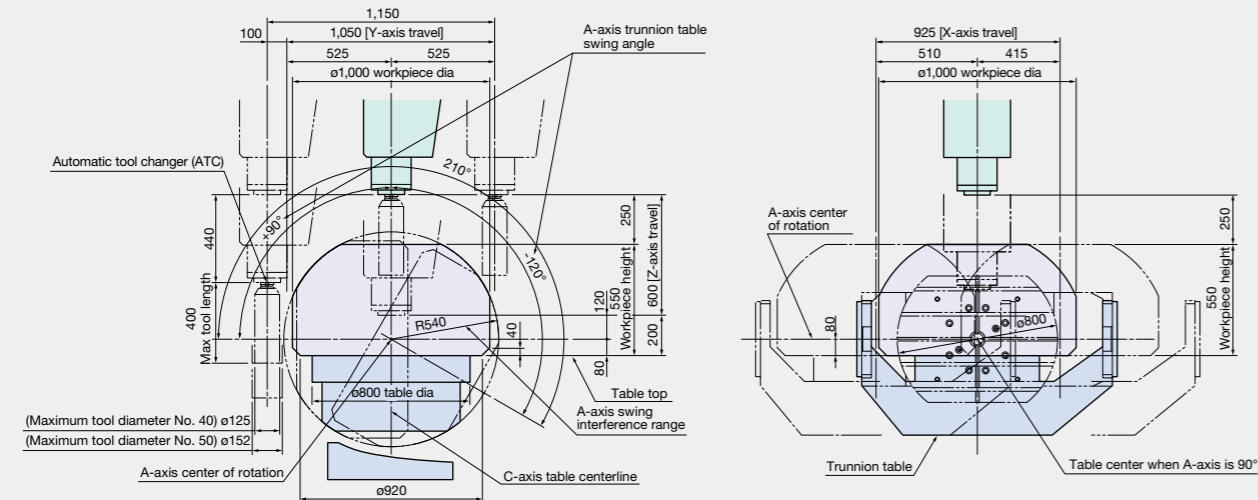

MU-8000V (P)

Max pallet load capacity: 550 kg

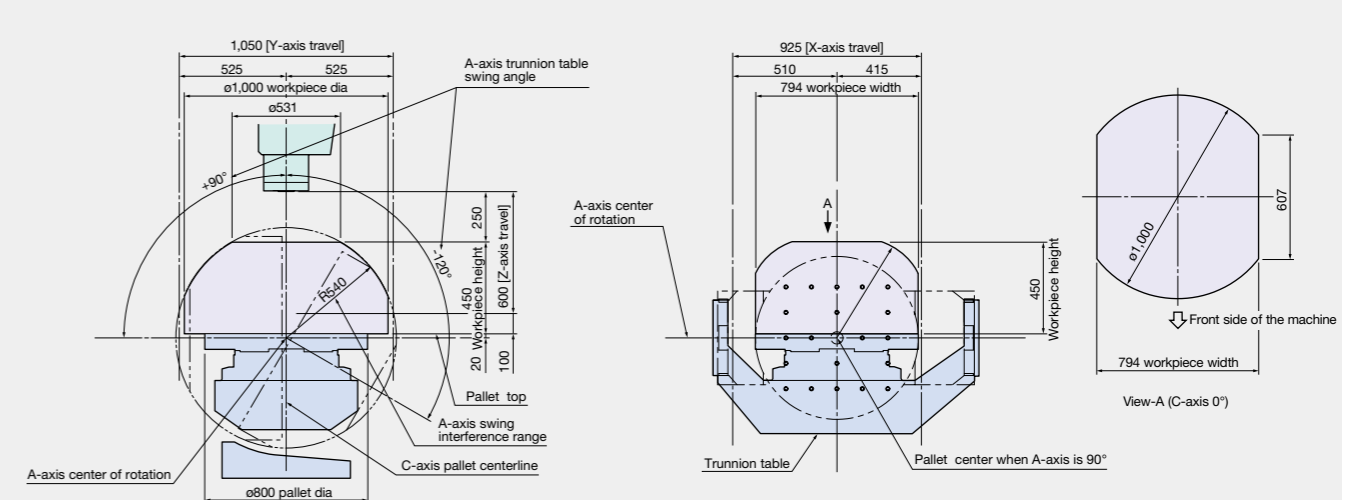
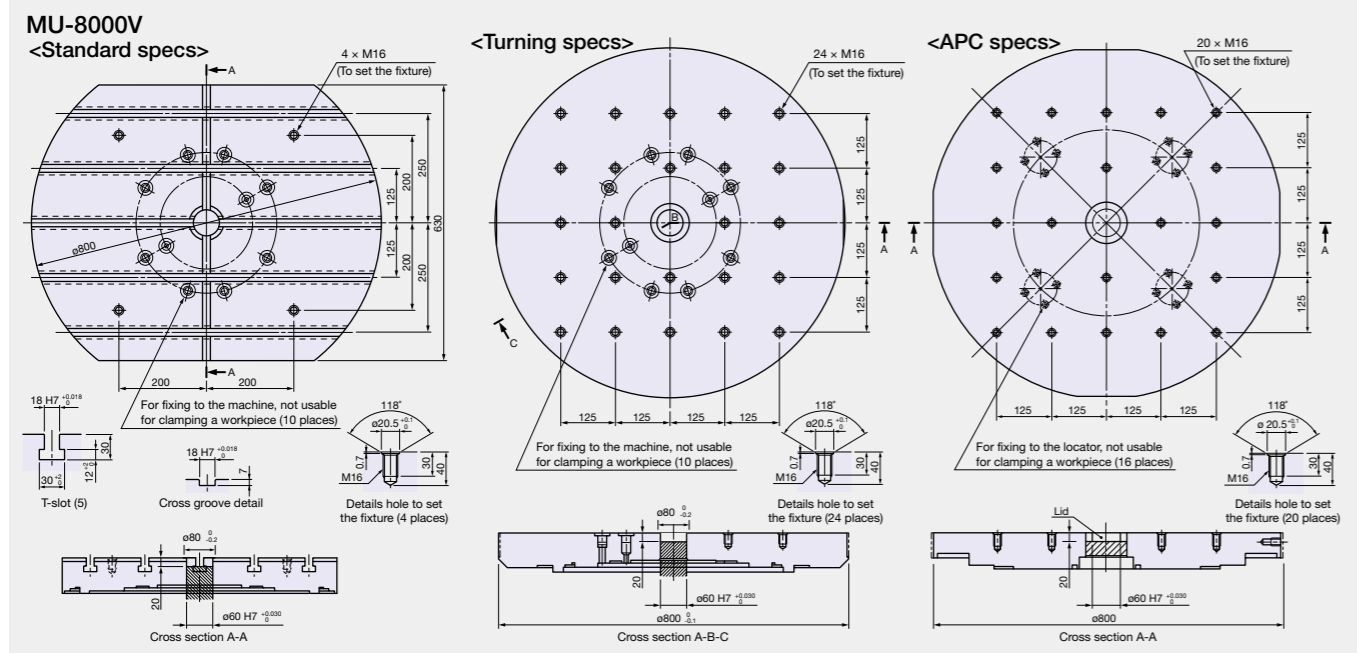
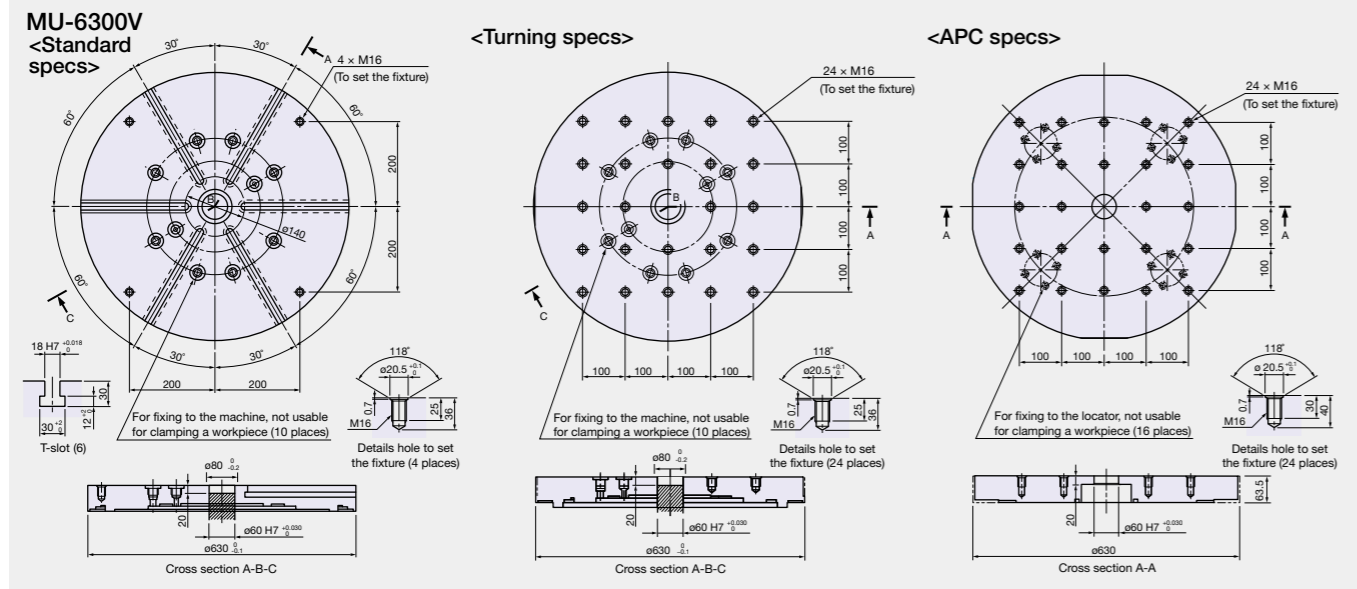
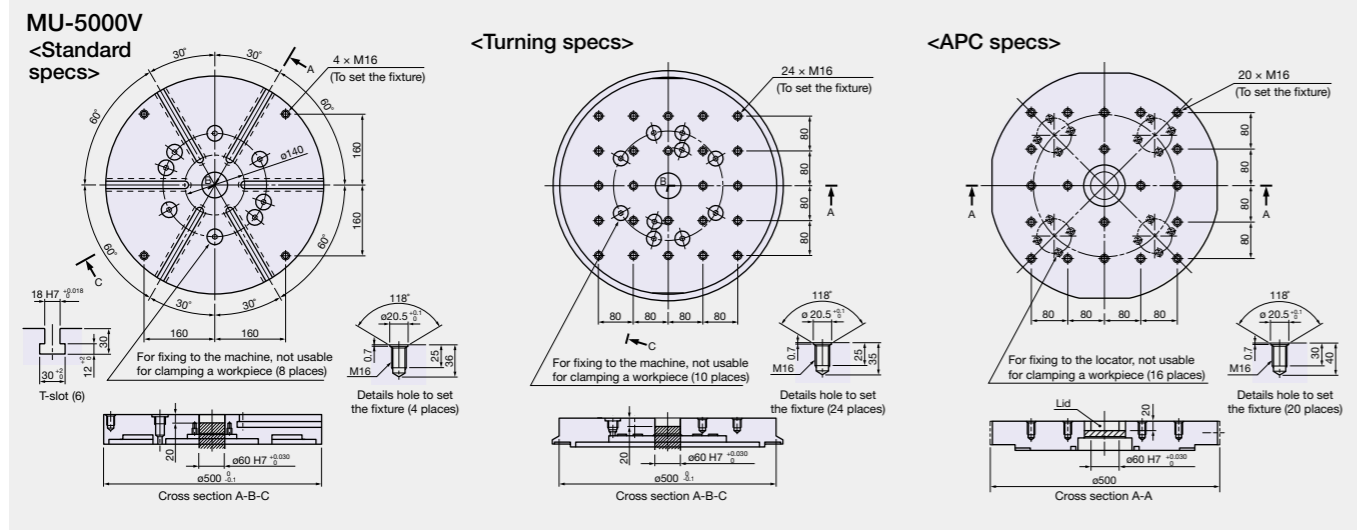
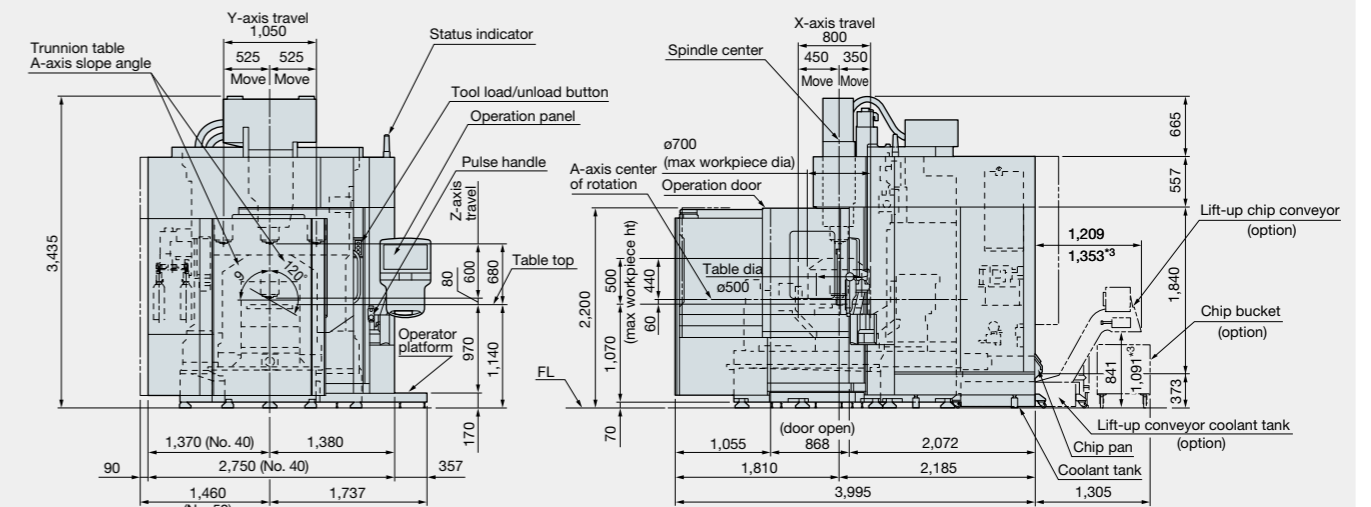
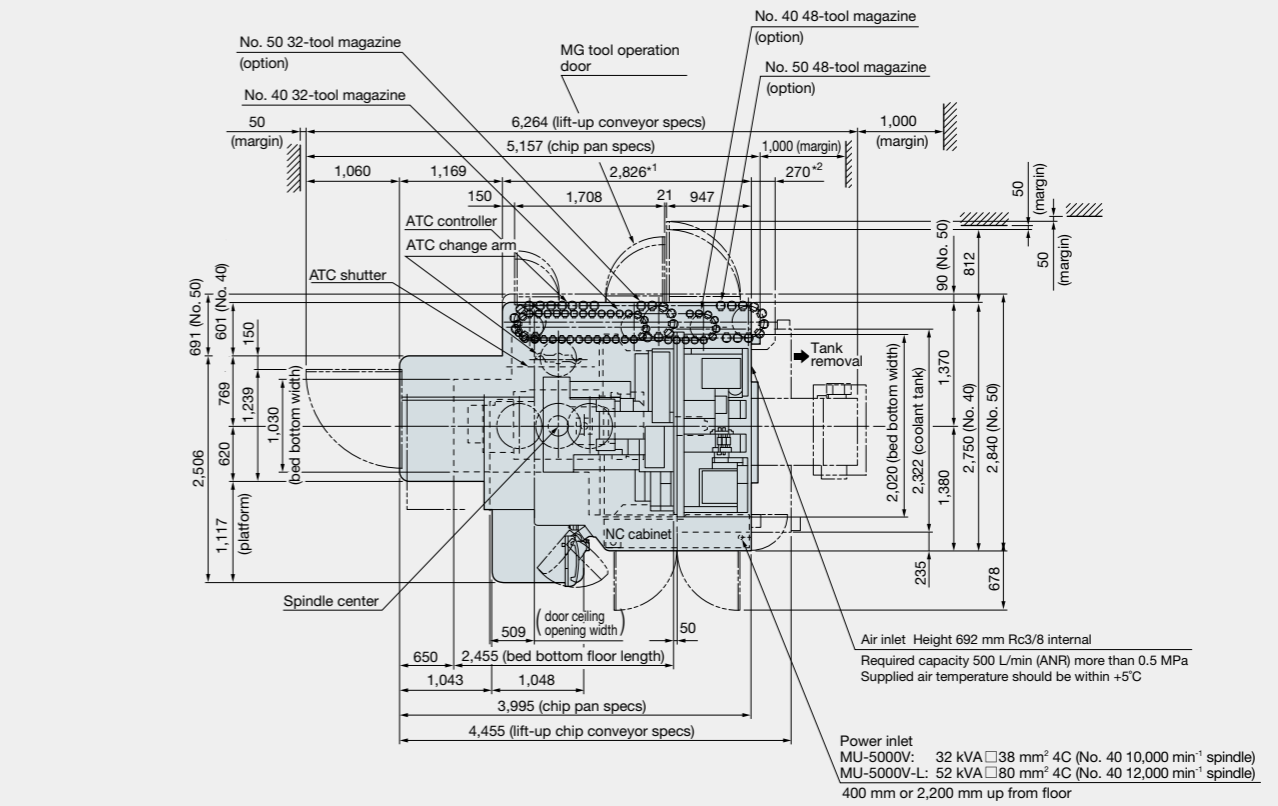

Table dimensions

Unit: mm



MU-5000V
Dimensional and installation drawings



- *1. No. 40 32/48-tool magazine, No. 50 32-tool magazine
- *2. No. 50 48-tool magazine
- *3. Floor lift-up chip conveyor
Height: 1,000 mm

Unit: mm

MU-6300V
Dimensional and installation drawings

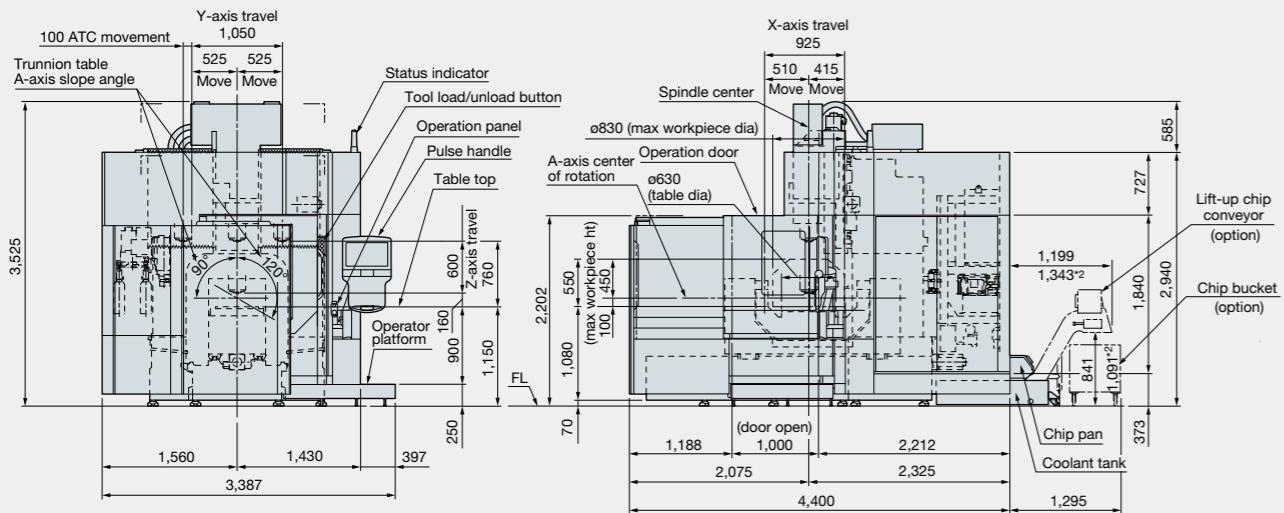
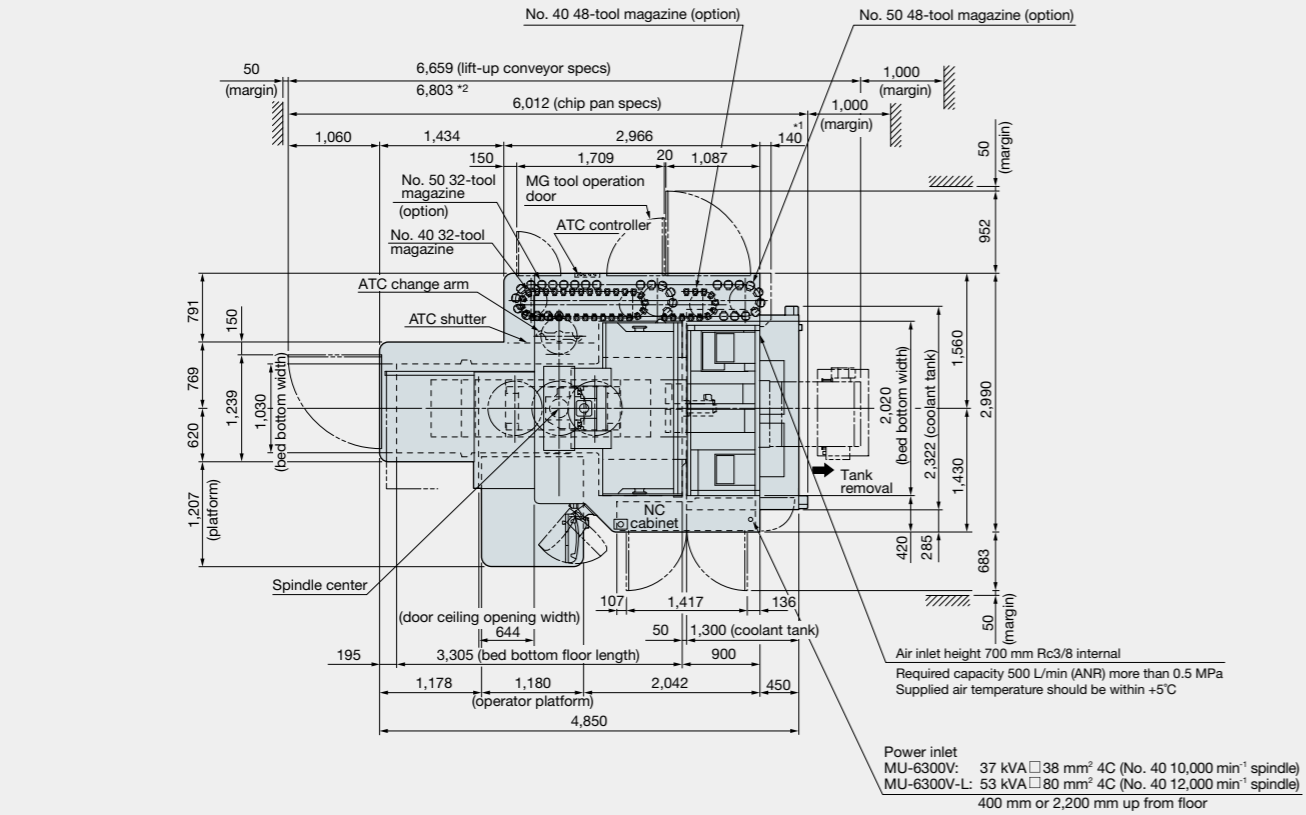

*1. No. 50 48-tool magazine
*2. Floor lift-up chip conveyor
Height: 1,000 mm

Unit: mm

MU-8000V
Dimensional and installation drawings

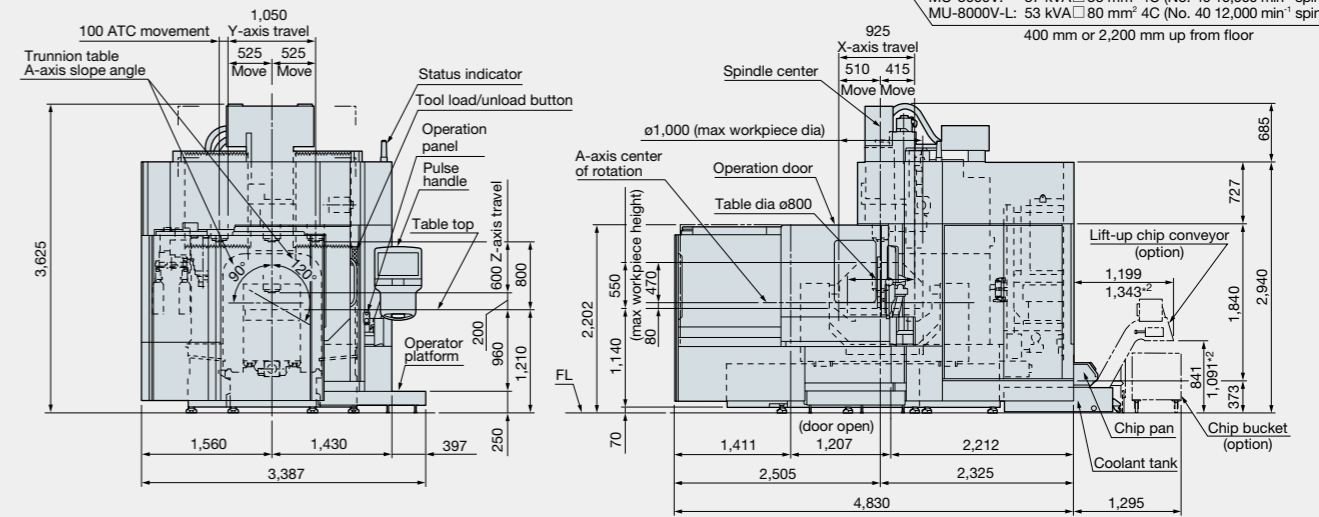
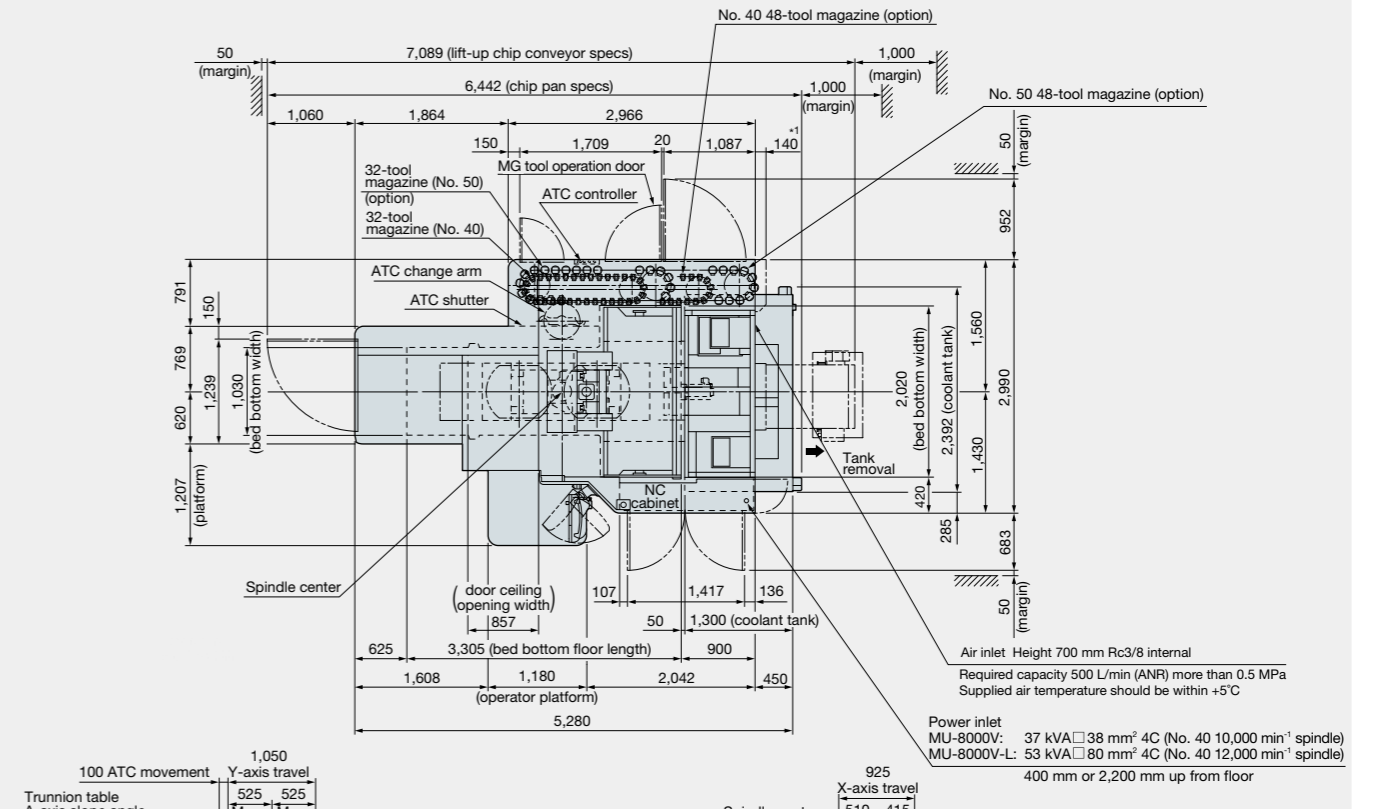

*1. No. 50 48-tool magazine
*2. Floor lift-up chip conveyor
Height: 1,000 mm

Unit: mm

MU-5000V 2-pallet APC
Dimensional and installation drawings

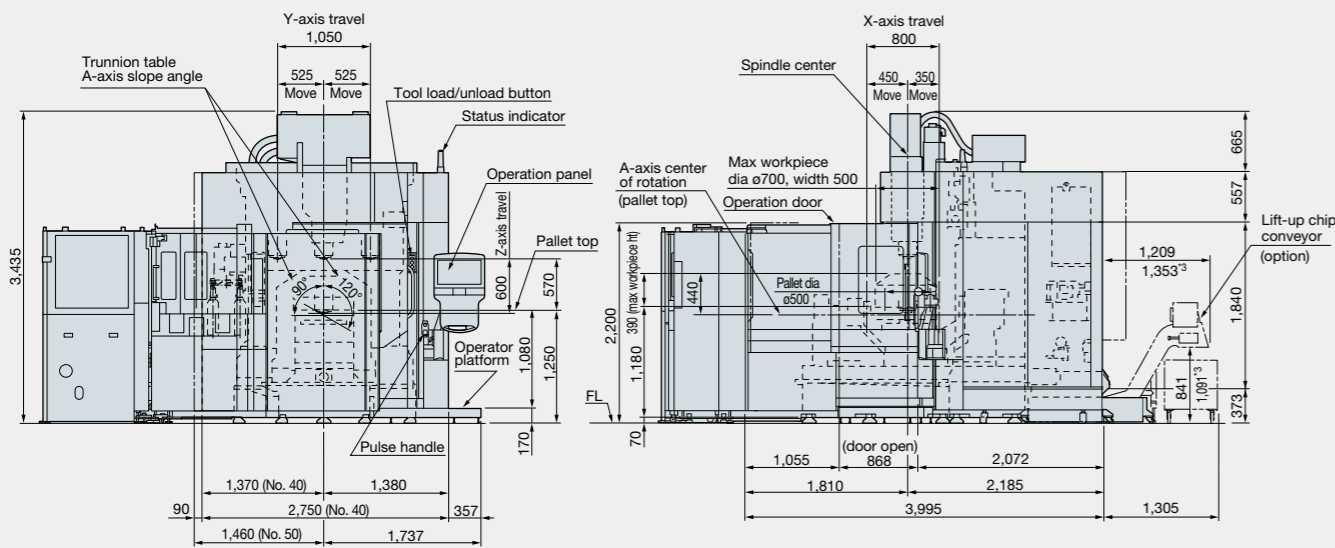
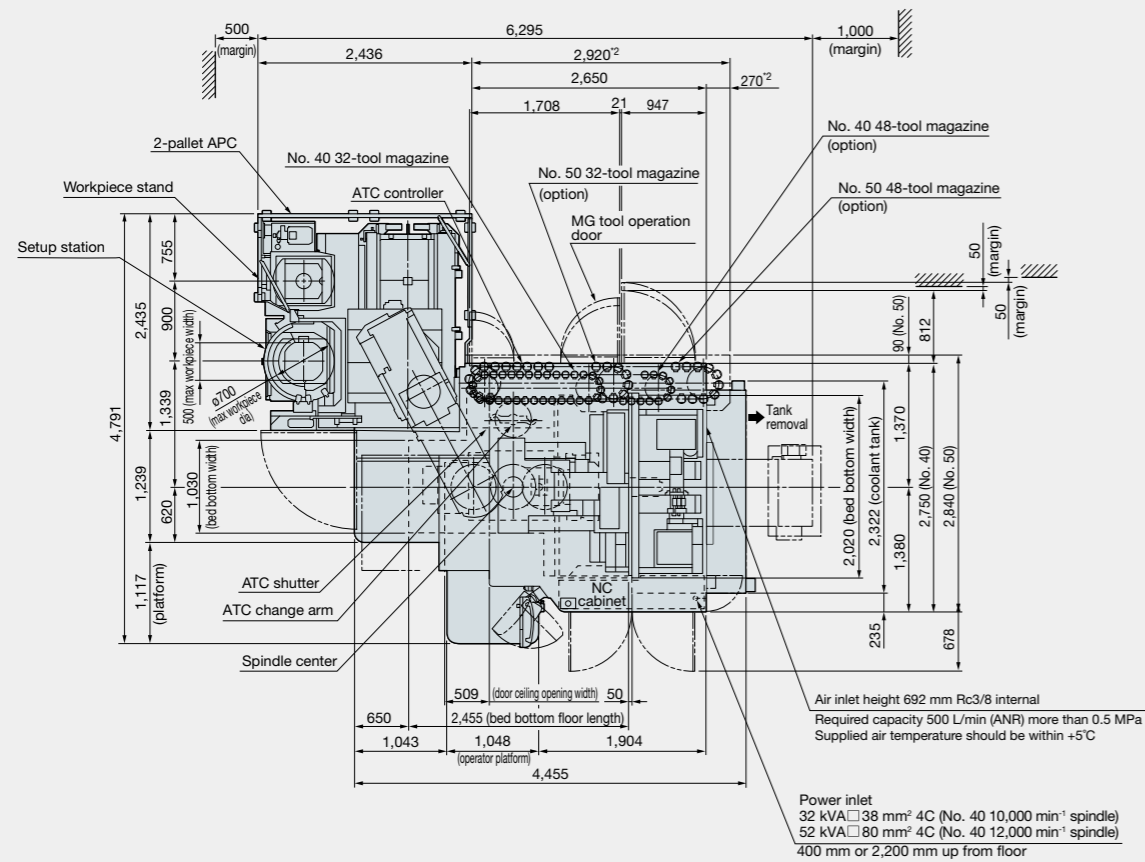

- *1. No. 40 32/48-tool magazine, No. 50 32-tool magazine
- *2. No. 50 48-tool magazine
- *3. Floor lift-up chip conveyor
Height: 1,000 mm

Unit: mm

MU-6300V 2-pallet APC
Dimensional and installation drawings

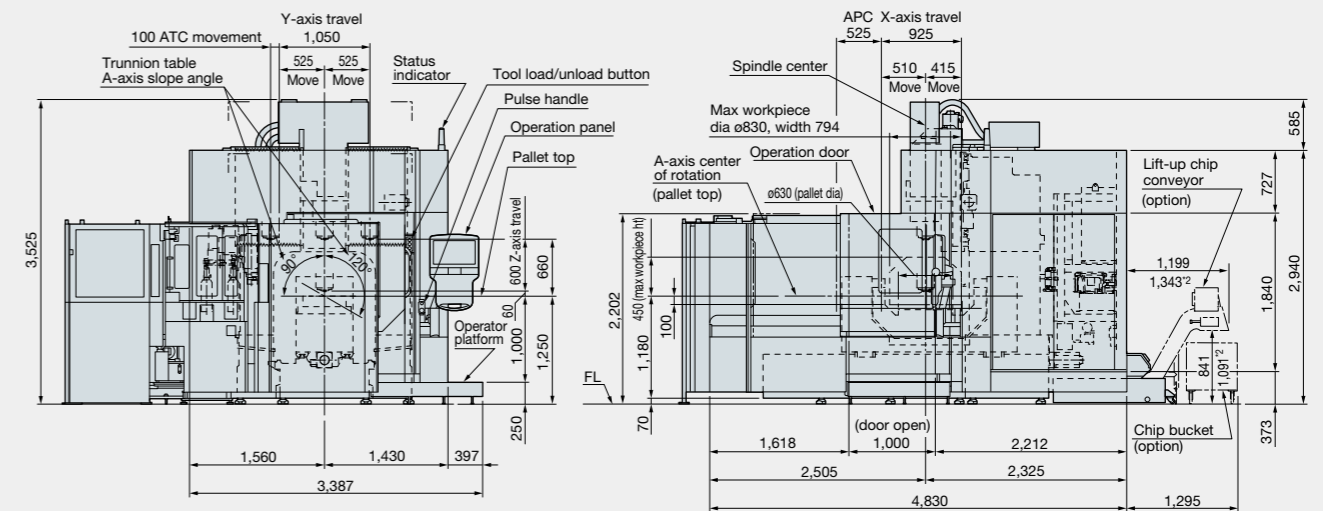
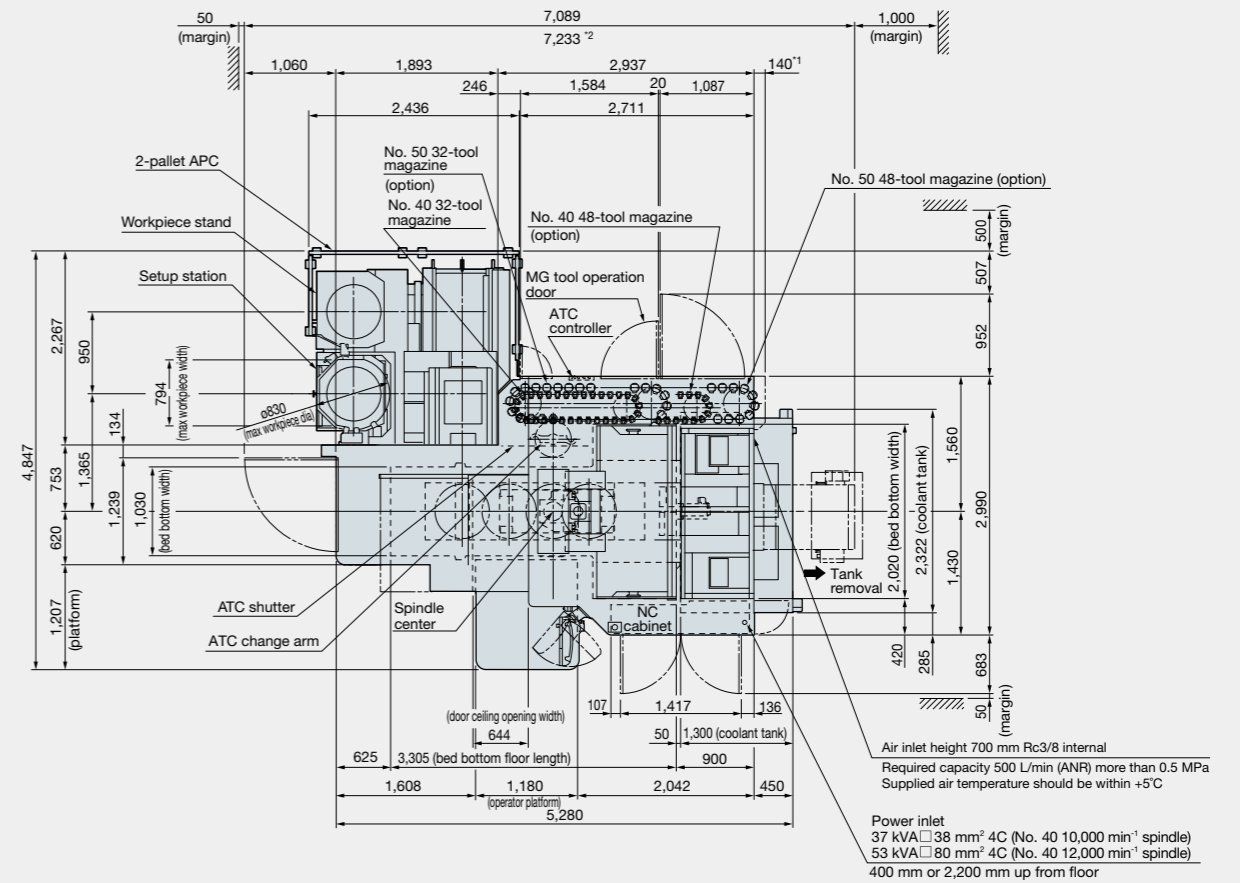

- *1. No. 50 48-tool magazine
- *2. Floor lift-up chip conveyor
Height: 1,000 mm

Unit: mm

MU-8000V 2-pallet APC
Dimensional and installation drawings

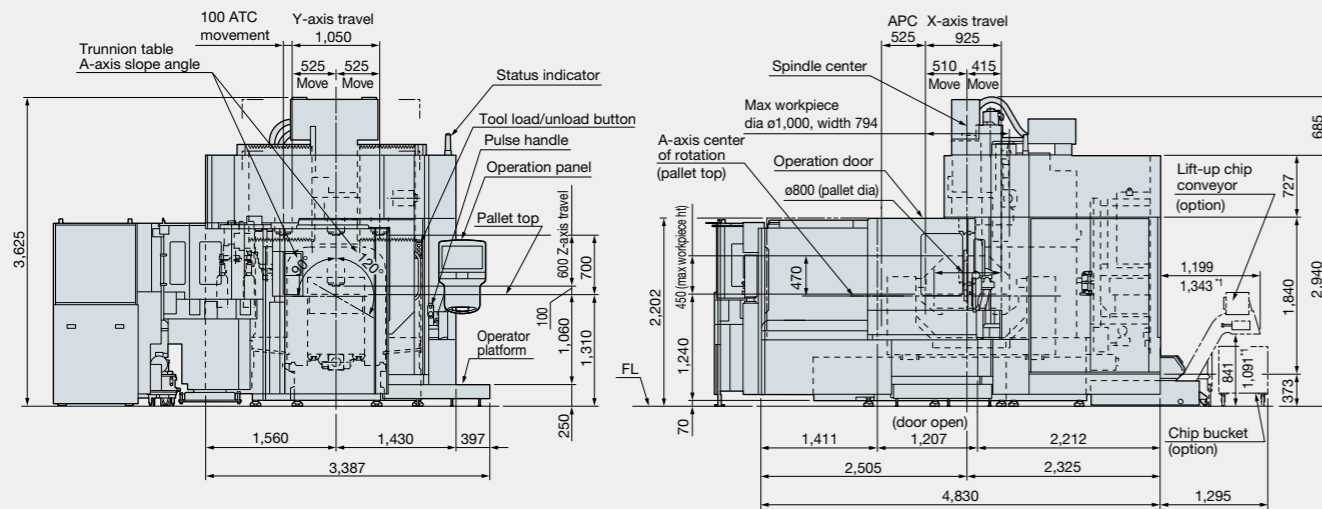
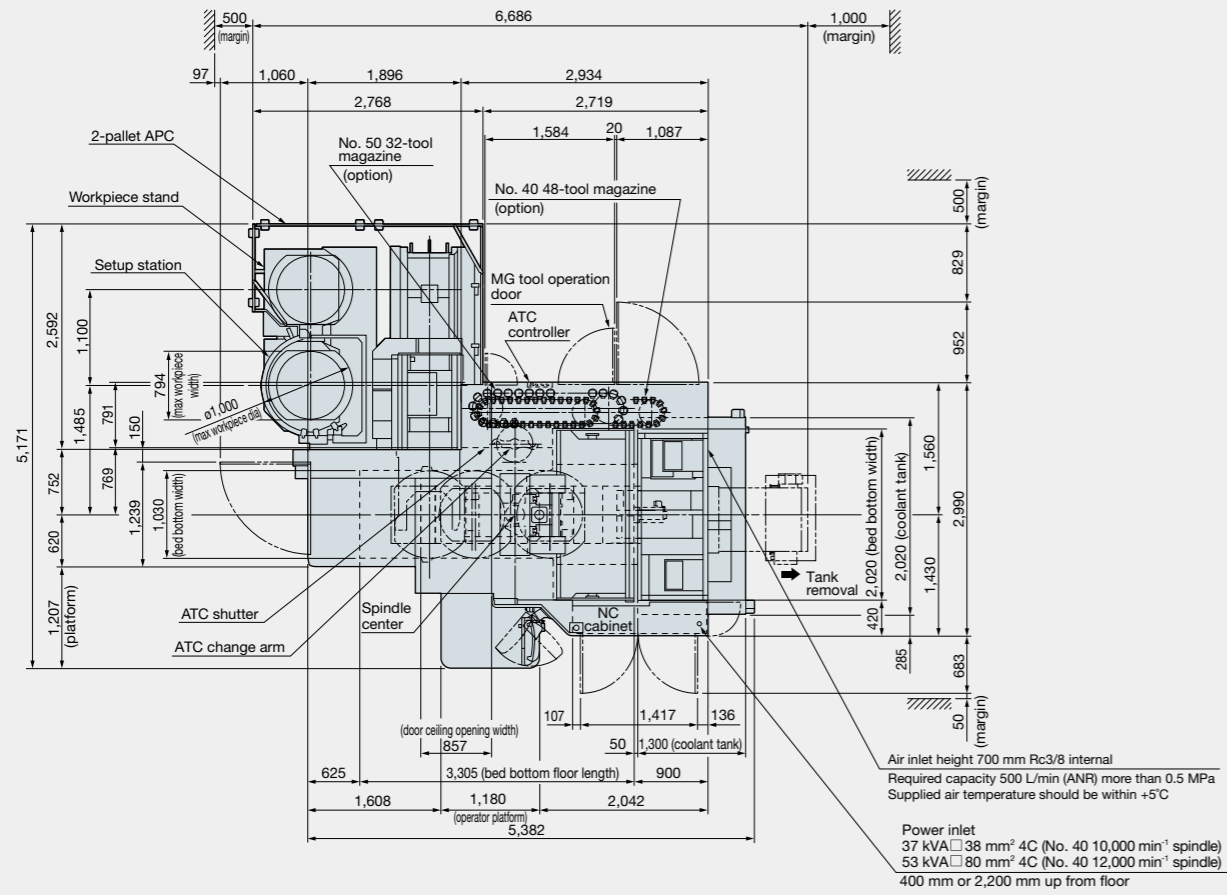

*1. Floor lift-up chip conveyor
 Height: 1,000 mm

Unit: mm

When using Okuma products, always read the safety precautions mentioned in the instruction manual and attached to the product.

●The specifications, illustrations, and descriptions in this brochure vary in different markets and are subject to change without notice.
Pub No. MU-V Series-E-(9b)-350 (Aug 2023)



OKUMA Corporation

Oguchi-cho, Niwa-gun,
Aichi 480-0193, Japan
TEL: +81-587-95-7825 FAX: +81-587-95-6074

This product is subject to the Japanese government Foreign Exchange and Foreign Trade Control Act with regard to security controlled items; whereby Okuma Corporation should be notified prior to its shipment to another country.